



FOR MORE THAN 25 YEARS WE HAVE BEEN WORKING  
CLOSE TO PEOPLE WHO RESEARCH, PRODUCE AND LOVE THE ORGANIC FARMING.



THE BIOLOGICAL FOR TRADITION  
[www.molinograssi.it](http://www.molinograssi.it)

The professional information network magazine for pasta manufacturers

- [www.pastaria.it](http://www.pastaria.it)
- [www.pastariahub.com](http://www.pastariahub.com)
- [www.pastabid.com](http://www.pastabid.com)



# Kronos<sup>®</sup>

## Better a seed than a ship.



The Kronos project. It originated from a collaboration with Albert Carlton, an American breeder, father of Desert Durum from Arizona, the durum wheat of high quality, imported from the best Italian pasta factories to produce premium pasta. Molino Grassi since 1992 has managed to have the exclusive copyright to reproduce the

seeds and cultivate them in Italy, adopting and improving farming techniques adapted to the Mediterranean climate, thus keeping the organoleptic features intact. Kronos is a durum wheat with a unique protein content, resistance to cooking, taste and color, ideal for tasty and always al dente pasta.

Per saperne di più: [www.molinograssi.it](http://www.molinograssi.it)





# Colophon

Pastaria International DE  
1/2024  
January



## PUBLISHER

**Kinski Editori S.r.l.**

*registered office*

Via Possioncella 1/1 • 42016 Guastalla

*operational headquarters*

Via Dall'Aglio 21/2 • 43122 Parma (Italy)

tel. +39 (0)521 1564934

fax +39 (0)521 1564935

Email [redazione@pastaria.it](mailto:redazione@pastaria.it)

ROC no. 23238

## EDITOR-IN-CHIEF

Lorenzo Pini

## COPYRIGHT ©

Being as we firmly believe that the sharing of information, ideas and knowledge can help make the world a better place, circulation of this magazine is not only allowed but is actually encouraged and incentivized. You can pass the magazine on to your friends and acquaintances, print it, distribute it, include a download link for it on your website, share it on your social networks and so on, as long as distribution is always without charge and no amendments are made to the original.

## INTERNET SERVICE PROVIDER (ISP)

xPlants.it (Levata di Curtatone, Mantova)



## Filled Pasta Equipment

### Filled Pasta Line

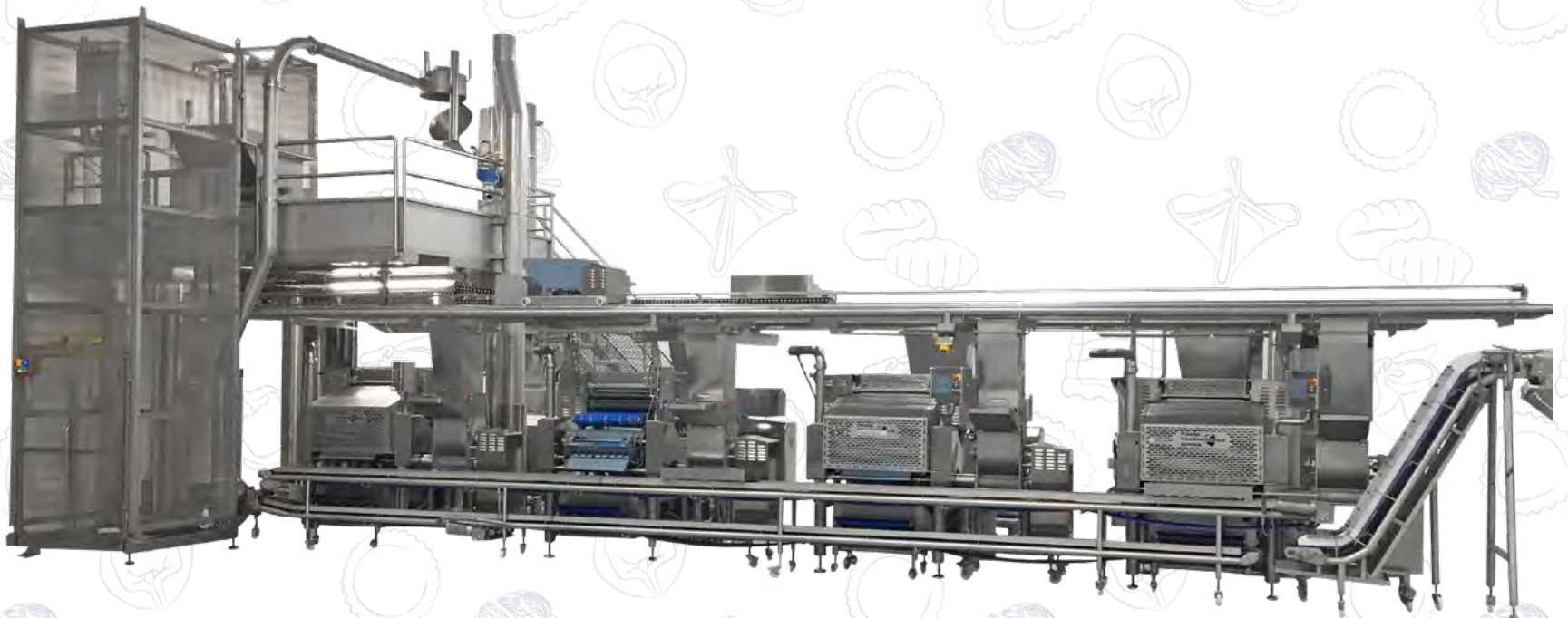

FAD Ravioli Forming Machine

FA Cappelletti Forming Machine

FJS300 Special Forming Machine



## Description

- Easy access for cleaning and maintenance
- Made of stainless steel AISI 304 and fully wash-down with high-pressure water and detergent
- Control panel with user-friendly interface to control the recipes and the production parameters of the machine and its accessories
- Hygienic design
- Quick die change with no tools
- Lubricating system with central unit placed on the cover, easily accessible from the carter

Follow Us:





# Patrons & Sponsors



# Patrons

Pastaria has obtained the patronage of the most prestigious national and international pasta manufacturer associations.

## Pastaria patrons



qualità, gusto e piacere

# Sponsors

The information and professional update resources that are part of the Pastaria network are freely distributed without charge thanks to the collaboration and support of leading companies operating on an international level to supply ingredients, semi-processed products, equipment and systems for manufacturing fresh/dried pasta, gnocchi and ready meals.

## Pastaria sponsors

### Main sponsors



Creiamo qualità



## Leading sponsors



## Sponsors

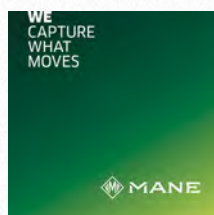



# FIERA PASTARIA

INTERNATIONAL PASTA FACTORY  
SUPPLIERS TRADE FAIR **& FESTIVAL**

**A single trade fair for  
all pasta factory suppliers.  
Together at the eighth  
Pastaria Festival.**

Come to Fiera Pastaria and visit the stands of **international suppliers** of ingredients, flavourings, semi-finished products, machinery, equipment, accessories and services for the **production of pasta**.

Join us to **take part** in the myriad meetings, seminars, presentations and round tables on pasta that make up the **Pastaria Festival** programme.

To book an exhibition space: **T. +39 (0)521 1564934**  
For information: **info@pastaria.it**

**STAZIONE LEOPOLDA**  
**FLORENCE, 20-21 MAY 2024**  
**SAVE THE DATE**

Organised by

**Pastaria**

**PASTARIA  
FESTIVAL**  
Sharing know-how on pasta manufacturing

With the collaboration of

**abimapi**  
COM.BR

**APPAFRE**  
Associazione produttori pasta fresca  
della piccola e media impresa

**apff**  
Associazione  
Produttori  
Pasta Fresca

**IPO**  
INTERNATIONAL  
PASTA  
ORGANISATION

**UN.A.F.P.A.**  
Unione Nazionale  
Associazioni Produttori  
Pasta Fresca

**Unione  
Italiana  
Food**  
qualità, gusto e piacere

**UIFRA**

# 1

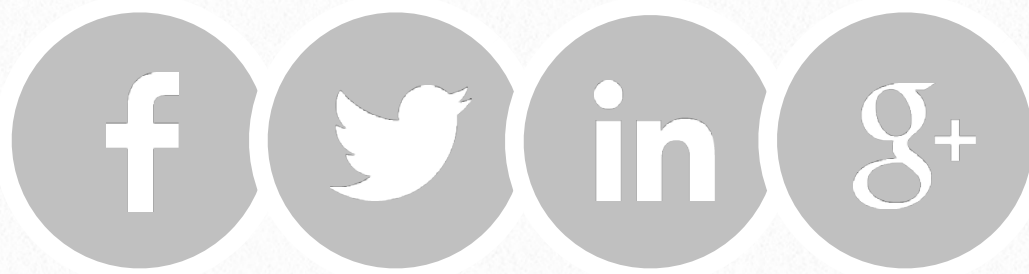

## The impact of drying processes on the organoleptic characteristics of durum wheat pasta

Vanessa Giannetti, Maurizio Boccacci Mariani  
Sapienza University of Rome



Studying the aromatic profile represents an important qualitative assessment, on the basis of which the thermal history of pasta can be monitored through the presence in the finished product of compounds formed/degraded during the drying stage. The objective of the research, presented at the conference *Dry pasta: quality, innovation and technological aspects of the process*, held during the Pastaria Festival 2023, is to identify in the flavour, through a multivariate analysis, new process and/or product markers capable of discriminating the products based on their heat treatment.

## **Introduction**

Pasta falls under the scope of Italian Law no. 580 of 4 July 1967 as subsequently amended and supplemented, which sets out a fundamental rule, specifically that durum wheat semolina and water are the only two ingredients used to produce dried pasta sold in Italy. The above law underpins the quality standards of Italian pasta, contributing to maintaining its international reputation as a high quality product.

While such legislation sets out very specific requirements regarding the quality properties of the ingredient to be used, it poses no restrictions on the production technologies selected for pasta-making. Nevertheless, the quality of the pasta, as well as the properties of the ingredients used, is affected by process conditions, which may impact the components of the semolina in a wide range of ways including, for example, altering the aromatic profile of the finished product or influencing the outcome of the competition between starch and protein during cooking. As such, the various types of heat treatment significantly affect the quality of the end product. Pasta drying processes are mainly differentiated on the basis of the temperature applied and the process duration, distinguishing between the more traditional low-temperature drying process (LT-Lt, Low Temperature-Long time) on the one hand, and rapid-drying processes involving more modern technologies (HT/VHT-St, High Temperature/Very High Temperature-Short time) on the other.

### **Drying and pasta quality**

The quality of a product, as defined by UNI EN ISO standards, is determined by a subjective component – i.e. what the consumer wants (perceived quality) – and an objective component, involving a set of technological quality and safety criteria pursued by the industries. A third component also contributes to determining the "overall quality" of a product, and specifically direct and transparent communication between the manufacturer and the consumer. The inclusion of voluntary statements on packaging is an example of such communication. It is clear, then, that

**ANSELMO**



**ANSELMO  
BRAIBANTI**



**FEN**



**ANSELMO  
LTA**



**OMAR**



**5 technologies**

perfectly matched  
to be your partner  
for **dry pasta, fresh pasta and snacks**

**ANSELMO GROUP**

*complete solutions for food industry*

[www.anselmoitalia.com](http://www.anselmoitalia.com)

**ANSELMO IMPIANTI SRL** - Via Fossano, 33 - Bene Vagienna (CN) - ITALY | Tel. +39 0172 654755 - Fax + 39 0172 654811

**LTA** - Via dell'Industria, 11 - Thiene (VI) - ITALY | Tel. +39 0445 370993 - Fax +39 0445 813114

**FEN IMPIANTI SRL** - Via Sole, 72 Tezze sul Brenta (VI) - ITALY | Tel. +39 0424 868711 - Fax +39 0424 868777

**OMAR IMPIANTI SRL** - Via Stelloni, 39/I - 39/O - Sala Bolognese (BO) - ITALY | Tel. +39 051 6814821 - Fax +39 051 727354

product quality results from the coexistence and convergence of a set of numerous, heterogeneous factors. As regards pasta, the factors that most contribute to its subjective quality are appearance, consistency of colour, firmness during cooking, texture, and price; its objective quality, on the other hand, are determined by the type of durum wheat used and the manufacturing process conditions applied. As such, each of these parameters determine a different quality standard for the finished product. Of all the above factors, the choice of production process conditions is undoubtedly fundamental. This is because, despite being a technological parameter, it has a significant influence on various aspects of the finished product including, for example, firmness during cooking and the aromatic profile which, as already noted, contribute to the consumer's perceived quality. Alongside food safety and nutritional properties, governed by the relevant legislation and underpinning the concept of quality for both the consumer and the manufacturer, organoleptic properties can play an essential role in consumer preference for one product over another. This is unsurprising given, first and foremost, that as well as satisfying the palate and olfactory system, flavour also

contributes to providing information on the drying processes used during production which, as stated above, have a tangible effect on the end product.

It is generally true to state that the more extreme drying technologies (HT/VHT-St) guarantee standard product quality, hygiene, a long shelf-life, firmness during cooking, and a reduction in the costs, times, and size of the dryers, therefore offering benefits to the consumer but, above all, to the manufacturer. That said, slow drying (LT-Lt) offers other, not insignificant, benefits. For instance, it preserves organoleptic properties such as aroma (perceivable through taste and smell) and appearance (identifiable by a consistent straw-yellow colour, attributable on the one hand to preservation of the carotenoids, and on the other to the fact that the Maillard reaction does not reach the more advanced stages, thus avoiding the production of by-products that give the finished product its characteristic brownish yellow colour). It also preserves the nutritional properties of the product (for example ensuring a higher content of essential amino acids such as lysine, thermolabile vitamins, and methionine). Additionally, it can only be applied if the ingredient is of excellent quality and, finally, the finished product contains a limited number (or lower concentration) of



# CIBUS

22<sup>ND</sup> INTERNATIONAL  
FOOD EXHIBITION

PARMA.7|10 MAY.2024

WELCOME TO  
FOODLAND

[cibus.it](http://cibus.it) | [cibus@fiereparma.it](mailto:cibus@fiereparma.it) | follow us on [f](#) [@](#) [t](#) [in](#)



by-products of the Maillard reaction, some of which can be potentially harmful. Given the notable benefits, the use of traditional drying may be considered an added value for the end product in terms of quality. In light of this, monitoring the drying process could lead to a more comprehensive characterisation of the quality of the pasta, while also making it possible to consider the influence of temperature and duration of the process on the organoleptic and nutritional properties of the end product.

### **The need for new quality markers**

In order to ensure that the quality standards of a food product are met, parameters must be identified that can be monitored and measured objectively using common indicators and methodologies. With regard to pasta, traditional examples exist, such as colour and cooking performance. It may, however, be useful to identify new product and/or process quality markers, in order to also assess the organoleptic, nutritional, and technological aspects, often overlooked by conventional criteria.

The literature features an increasing number of studies promoting innovative indicators – mainly selected from among the products of the Maillard reaction and the lipid peroxidation reaction – which

affect pasta during the production process and, as such, may provide additional information with regard to overall quality. The role of furosine ( $\epsilon$ -furoylmethyl-lysine), for example, as a heat treatment marker has been established for some time. Indeed, the latter can provide information both on the protein content of pasta – particularly with regard to lysine loss and, as such, the nutritional loss suffered – and on its AGE (advanced glycation end-product) content, associated with the onset of various conditions in humans.<sup>[1,2]</sup> Nevertheless, when extreme drying techniques are used, an estimate of furosine alone is no longer reliable for the purposes of the above assessments, as the Maillard reaction moves towards more advanced stages, and the Amadori products (indirectly quantified by way of an acid hydrolysis reaction that leads to the formation of furosine) transform into other compounds.<sup>[3,4]</sup> It is in the above context, specifically, that identifying additional markers can be helpful. Specific substances in the aromatic profile of pasta, in association with furosine and traditional indicators, can indeed serve as process markers, allowing samples to be distinguished based on the type of drying applied and, therefore, enabling the production process to be monitored. They may additionally, or alternatively, serve as

# TECHNO BINS

From semolina to pasta  
a unique storage specialist

Our experience is the result of forty years of work serving the milling industry and the main plant builders in the pasta sector, which allows us to customize storage systems to serve the entire production chain of the pasta factory.

The only company which supplies all types of metal silos, round and prismatic - smooth and corrugated. We will find the suitable solution to optimize your spaces and prevent the accumulation of dust and cross-contamination between products.



*Innovative battery of completely smooth and self-cleaning pasta cells, compliant with the main HACCP and MOCA regulations and subjected to quality control - ISO 9001 and UNI EN 1090 certified company.*



**TECHNOBINS** s.r.l.

Via R. Cartesio, 2  
42122 Reggio Emilia - Italy  
Phone +39 0522 943002  
info@technobins.it



[www.technobins.it](http://www.technobins.it)



quality markers, providing added value to pasta that retain their sensory and nutritional qualities to a greater degree.<sup>[5,6]</sup>

### **The Maillard Reaction and lipid oxidation in pasta**

The Maillard Reaction (MR) is a complex series of glycation processes that occur following the interaction between the carbonyl groups of reducing sugars and the amino groups of proteins, typically stimulated during heat treatment of foods. In the 1950s, American chemist John E. Hodge outlined the various processes in the reaction, dividing them into three distinct stages during which the starting compounds lose water molecules, transforming into more unsaturated products with the formation of combined systems.

The fundamental conditions for triggering the above reaction – and specifically the presence of reducing sugars and protein, the achievement of a high temperature and low water activity – are met during pasta production, and the MR is evident on various levels. As such, the MR plays a fundamental role in the drying process, particular at the final stages when the percentage of water in the food decreases. Low-temperature, long-time treatments therefore generally only give rise to the initial stages of the MR, with the

development of intermediate Maillard products that give the pasta an initial light colouring and notable aroma. Rapid drying, on the other hand, involves the final stage of the reaction being reached, with the formation of melanoidin, resulting in a dark yellow colour and large aromatic compounds, some of which may be unpleasant and toxic.

An analysis of pasta produced at different temperatures and according to different drying times indicates a qualitative and quantitative difference between the MR products that develop in the flavour. Such products may, therefore, be effective candidates for use as process and/or product quality markers.<sup>[7]</sup>

The lipid peroxidation reaction, on the other hand, involves the multi-step chemical process in which oxidating agents (often reactive to oxygen) and free radicals attack lipids with double bonds (and unsaturated fatty acids in particular) present in the food matrix. The factors that encourage the reaction are exposure to light, availability of oxygen (air), heat and moisture, long storage periods, and the presence of organic and/or inorganic catalysts. This oxidative degradation process leads to the formation of aromatic compounds that give rise to unpleasant flavours and smells and, therefore, to the



WE  
CAPTURE  
WHAT  
MOVES



Family-owned company, offering natural flavouring solutions since more than 150 years, MANE is your partner for **high-quality ingredients for pasta**.  
MANE ITALIA will look after you with the best possible local service.

Contact:  
[emea.savoury@mane.com](mailto:emea.savoury@mane.com)



deterioration of the original organoleptic properties, leading to loss of food quality. The composition (and, by extension, nutritional value) of dried pasta is determined by the ingredient and, therefore, by the durum wheat lipid content (and unsaturated fats in particular); as such, pasta is subject to lipid peroxidation. The use of low temperatures in the drying process – which results in a shorter shelf-life than higher temperatures – lends itself to greater oxidative degradation. As such, as with MR products, because the presence of lipid peroxidation products differs qualitatively and quantitatively in pasta dried at different temperatures, they may also be valid candidates for use as process/product markers.

### **Characterisation of flavour according to drying type**

As mentioned previously, population of the flavour of pasta, and its source, will differ, qualitatively and quantitatively, based on the thermal history (and, therefore, the drying type) of the product analysed. According to studies carried out by our research group, pasta dried at a low temperature (LT-Lt) is mainly characterised by compounds resulting from lipid oxidation including, for example, hexanal, 1-hexanol, 1-octen-3-ol, 1-heptanol,

octanal, nonanal, 2-pentylfuran (generated by the oxidation of linoleic acid and oleic acid). As such, the characteristic classes in the flavour of pasta dried in the traditional way are alcohols, aldehydes and furanes. With regard to pasta dried at high temperatures (HT-St/VHT-St), on the other hand, the typical primary compounds are those resulting from the Maillard reaction, and specifically 2-furanmethanol, furfural, maltol, and Strecker aldehydes (e.g. acetaldehyde). As such, the characteristic classes of volatile substances in the flavour of pasta dried using more extreme methods are aldehydes, ketones and furanes.<sup>[8,9]</sup> The results are in keeping with the literature (all bibliographical references are included in our previously published works).

The experimental evidence obtained over the course of the studies is consistent with what has been outlined thus far, that drying under less extreme conditions gives rise to the development of aromas, but does not result in the more advanced stages of the Maillard reaction. This explains the abundance of compounds resulting from lipid oxidation, which occurs to a greater extent having not been blocked by the MR (and indeed, the shelf-lives of slow-dried pasta are shorter), while also explaining the limited presence of MR products resulting from the final

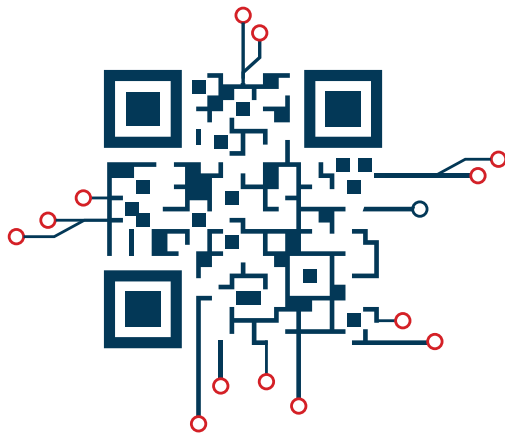

# RAM<sup>®</sup> | 50

ELETRONICA

1974/2024

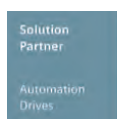

Via Ospedaletto km 1,700C.P. 325 76123, Andria (BT) | Italy  
Tel. +39 0883 553719/20 | [information@ramelettronica.it](mailto:information@ramelettronica.it) | [ramelettronica.it](http://ramelettronica.it)

stages of the process (large molecules, often undesired). Maillard products take centre stage, on the other hand, in the flavour of pasta dried under more extreme conditions, in which the high temperature gives rise to greater progression of the MR, which reaches more advanced stages, thus blocking oxidative degradation.

## Materials and methods

This study involved the analysis of one hundred samples of durum wheat spaghetti from five different brands (twenty samples per brand). The samples were obtained from large-scale retail supermarkets, and selected to ensure that at least ten packs from each brand came from different batches. The samples fall within the mid-range bracket available on the market (with prices of between € 1.50 and € 2.00 per 500 g pack). Only two of the brands include information on the label concerning the production process adopted, but neither specify the stage of the process to which the information on the pack (provided voluntarily by the manufacturer) refers.

Having been weighed and ground, the samples were analysed using GC-MS to determine their aromatic profile. Each sample was analysed in duplicate. The

HS-SPME/GC-MS method used was previously developed and optimised by our research group.<sup>[10]</sup>

## Results and discussion

This study forms part of a wider research project – embarked on a number of years ago by our working group – aimed at identifying new process and/or product/quality indicators that can distinguish between pasta according to the heat treatment used during production by characterising its aromatic profile and constructing chemometric classification models. In this context, the research set out here, which is still at an experimental stage, presents the status of the results obtained.

Following the gas-chromatography analysis of the samples, an initial qualitative assessment was performed, which involved drawing on the MiST (Mass spectrometry interaction Statistics) database to identify the characteristic compounds of the volatilome of each class of samples. The substances taken into consideration are those for which the probability of correct identification is relatively high, and specifically associated with an RSI  $\geq$  850. This enabled a list to be drawn up of the compounds that populate the flavour of each brand of pasta and,



# Italpast & Pastificio Artigianale Leonessa

**A collaboration dedicated to innovation and quality**

In 2024, coinciding with its fiftieth year of activity, co. Pastificio Artigianale Leonessa will inaugurate a new factory for the production and processing of various dry pasta shapes in Cercola, in the province of Naples.

For the occasion, the company chose Italpast to study, design and manufacture this new and important system, full of automation and technological innovations. The collaboration between the know-how of co. Leonessa and Italpast technological innovation is destined to write a new chapter in pasta excellence.

We are grateful to co. Leonessa for choosing Italpast and we are thrilled to be at their side in the realization of this ambitious project.

where possible, each was associated with its source and characteristic smell, with reference to the literature. This phase of the study is still under way, however, with greater population planned for each class of samples.

Two PLS-DA (Partial least squares-discriminant analysis) models were then constructed and validated. In the first model, the five classes associated with the five brands of pasta analysed were clearly separate in the multivariate space along the first three canonical variables (the directions of maximum discrimination), i.e. those that capture the dissimilarities among the samples ([Figure 1 left](#)). An assessment of the weights of the variables that define the various components made it possible to identify the compounds most responsible for discrimination of the samples; this assessment indicates a very high number of substances responsible for the separation of the data. As such, in order to be able to determine which among these substances were the most significant with regard to separation of the classes, a VIP (Variable importance in projection) scores analysis was carried out, which allows the VIP scores that explain how the various variables contribute to the discrimination to be assessed (phase of the study still

ongoing). The VIP scores are scaled to an average value of 1: all compounds with a score greater than 1 represent the variables that most contribute to the discrimination of the samples; the higher the VIP scores, the greater the weight of the variable in the separation. The results obtained indicate that the model constructed can associate an unknown sample with one of the five brands considered.

A second PLS-DA model was subsequently constructed, this time with two classes: one class (class 1) consisting of the samples of the only brand of pasta analysed that expressly states on the label that the slow-drying production process has been used, and the second class (class 2) consisting of all other samples from the remaining four brands. It is probably fair to assume that the pasta from these four brands is not slow-dried, given that slow-drying is not mentioned on the label, and is a factor regarded today as adding value to the product. This model has been designed with a view to identifying specific markers for differentiating pasta dried at low temperatures (LT-Lt method) from those dried at a high temperature (HT/VHT-St). [Figure 1\(right\)](#) presents a graphic of the model in which the samples are shown along the only canonical variable capable

# TECHNOLOGY, EFFICACY AND EFFICIENCY by LANDUCCI

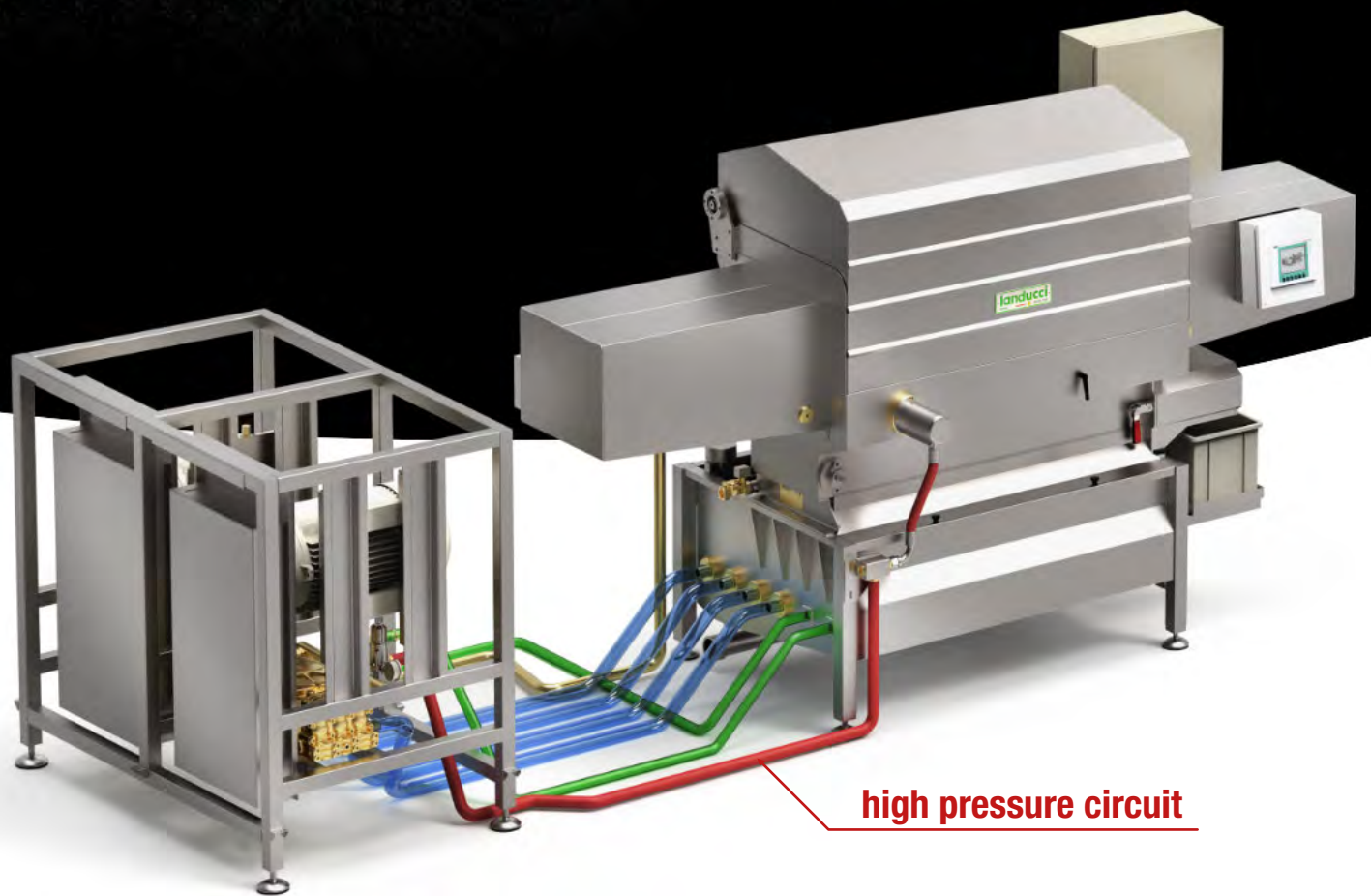

**Double pressure**  
**Double efficiency**  
**Saving water, energy and time**



Landucci s.r.l. - Via Landucci, 1 - 51100 Pistoia - Italia - Tel. + 39 0573 532546

[www.landucci.it](http://www.landucci.it)



of distinguishing the data, as there are only two classes. The LT-Lt samples are situated at the top, beyond the border between the two classes, corresponding to the positive values of the canonical variable scores; the samples of the remaining four brands of pasta, meanwhile, are positioned at the bottom, corresponding to the negative score values (with the exception of certain samples, associated in part with positive score values, but nevertheless remaining below the dividing line).

As already discussed with regard to the previous model, in order to interpret the model and, therefore, identify the compounds most responsible for discriminating between the samples, the weights of the variables that define the canonical variable must be assessed (phase of the study still ongoing). This second PLS-DA model can be used to focus on the slow-dried products, indeed it can associate an unknown sample with one of the two classes: class 1 (LT-Lt) or class 2 (HT-St/VHT-St). While the model constructed is associated with 100% correct classification, discriminating significantly between the two classes, it is nevertheless subject to the critical issue of assuming that all dissimilarity between the aromatic profiles of the samples is associated with the type of drying used.

This assumption is, however, certainly an approximation given that, as mentioned previously, other factors exist that contribute to determining the flavour (including, for example, the ingredient used). Nevertheless, it is true that the thermal history of the product is a significant factor in determining the aromatic profile, given the different impacts of the various heat treatments on the volatile compounds.

## Conclusions

This study, which is still ongoing, involved a HS-SPME/GC-MS analysis of the aromatic profile of dried durum wheat pasta products on the market, and the chemometric processing of the data with a view to discriminating between the products that underwent LT-Lt drying and those dried using HT-St/VHT-St methods and, subsequently, to identifying new process and/or product markers to be associated with the conventional markers, in order to determine the overall quality of the pasta.

The two PLS-DA models constructed and validated both demonstrated 100% correct classification, offering optimal results. It should be noted, however, that the first model would benefit from greater population for each class of samples (the

**DURUM WHEAT SEMOLINA.  
THE GREAT MASTERS OF PASTA  
CHOOSE **MININNI**.**

**INDUSTRIA MOLITORIA MININNI SRL**  
ALTAMURA (BA) - ITALY  
Tel. +39 080 3103625  
[www.molinomininni.com](http://www.molinomininni.com)



**Figure 1 (LEFT) PLOT OF PLS-DA MODEL WITH FIVE CLASSES; (RIGHT) PLOT OF PLS-DA MODEL WITH TWO CLASSES.**

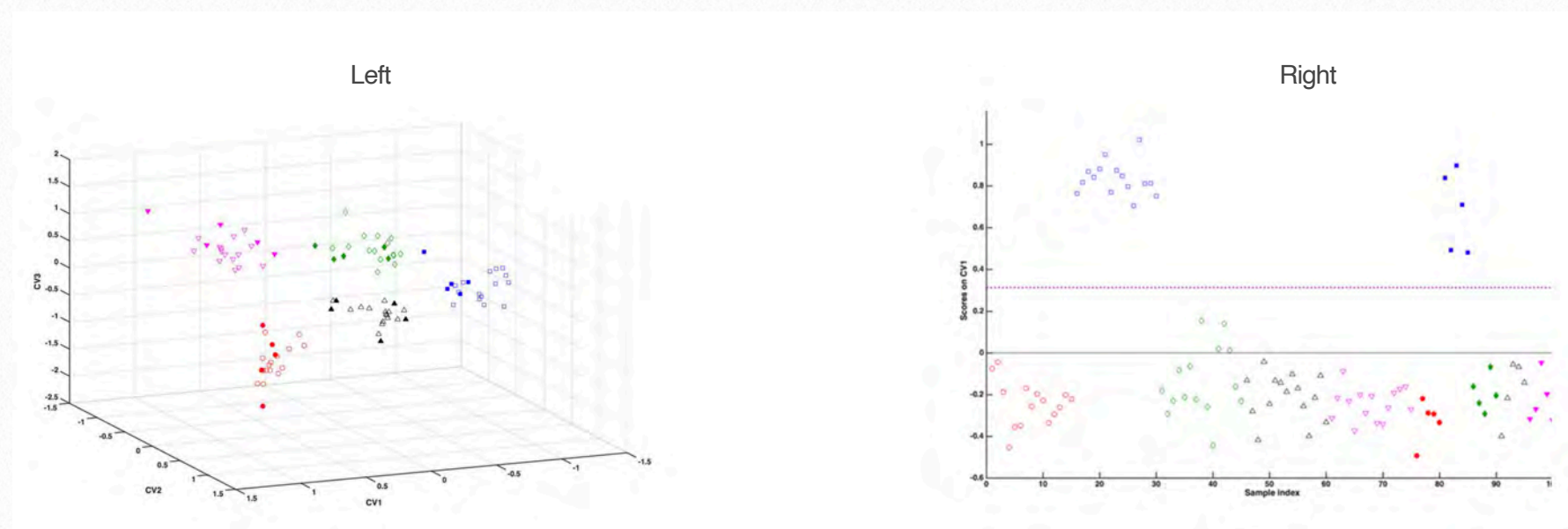

Each colour identifies a class (brand) of pasta. The "empty" symbols represent the samples used for the training set, while the "full" symbols represent the samples used for the test set.

model was constructed based on 20 samples for each class, and validated based on cross-validation); the second PLS-DA model, with two classes, meanwhile, involves the assumption that the dissimilarity between the aromatic profiles of the samples is exclusively associated with the type of drying used, and that only one class of samples has in fact been slow-dried, as this is stated on the label. However, as there is no legislative requirement to include the production method on the packaging, the production method is unknown unless the manufacturers voluntarily include such information.

Nevertheless, the results are satisfying, positively responding to the aims of the study and succeeding in identifying – by means of VIP scores analysis – potential process/product markers that can offer

added value to the pasta product in terms of quality. With a larger population of data and ingredient samples, and more comprehensive information on the production process, the models and results achieved could certainly be improved upon.

## Acknowledgements

A well-deserved thank you to our colleague Prof. Federico Marini (Sapienza, University of Rome) who collaborates with our research group, as a data curator, to produce scientific articles from which the primary research results underpinning this more communicative article has been extrapolated.

## Bibliography

All bibliographical references used for the present study are available in previous articles published by

# la baresina

## Gold 300



Regional pastas from A to . . .

# ZINDO

Pasta Machines & Processing

[zindo.it](http://zindo.it)

the authors' working group and listed below:

- [1] V. Giannetti, M. Boccacci Mariani, P. Mannino (2013). *Furosine as a pasta quality marker: evaluation by an innovative and fast chromatographic approach*. Journal of Food Science, 78(7), 994-999.
- [2] V. Giannetti, M. Boccacci Mariani, P. Mannino (2013). *Furosina come marker di qualità della pasta di semola di grano duro*. Tecnica Molitoria, 64(12), 1076-1088.
- [3] V. Giannetti, M. Boccacci Mariani, S. Colicchia (2021). *Furosine as marker of quality in dried durum wheat pasta: Impact of heat treatment on food quality and security - A review*. Food Control, 125, 108036.
- [4] V. Giannetti, M. Boccacci Mariani, S. Colicchia (2021). *Come valutare l'impatto termico subito dalla pasta di grano duro durante il processo di essiccazione? L'interesse della comunità scientifica sul ruolo della furosina come indicatore di qualità*. Tecnica Molitoria, 72(10), 47-65.
- [5] V. Giannetti, M. Boccacci Mariani, P. Mannino (2017). *Flavour e furosina come marker per valorizzare la tradizionale pasta di grano duro Made in Italy*. Tecnica Molitoria, 68(1), 4-17.
- [6] V. Giannetti, M. Boccacci Mariani, P. Mannino, E. Testani (2014). *Furosine and flavour compounds in durum wheat pasta produced under different manufacturing conditions: Multivariate chemometric characterization*. LWT- Food Science and Technology, 56, 15-20.
- [7] E. Testani, V. Giannetti, M. Boccacci Mariani, P. Mannino (2016). *Maillard reaction products as markers of the durum wheat pasta drying process*. Acta Alimentaria, 46(3).
- [8] V. Giannetti, M. Boccacci Mariani, F. Marini, A. Biancolillo (2021). *Effects of thermal treatments on durum wheat pasta flavour during production process: A modelling approach to provide added-value to pasta dried at low temperatures*. Talanta, 225, 121955.
- [9] V. Giannetti, M. Boccacci Mariani, G. Livi (2021). *Studio del profilo aromatico della pasta di grano duro per valutare l'influenza del trattamento termico sulle sue caratteristiche finali*. Tecnica Molitoria, 72(7), 35-47.
- [10] M. Boccacci Mariani, V. Giannetti, E. Testani (2014). *HS-SPME/GC-MS method to characterise the flavour of Italian pasta: potential application to assess the quality of the products*. Food Analytical Methods, 7, 64-72.



# DEMACO Titan Series

## Superior Pasta Quality



**FLOW X** is **DEMACO's** proprietary dough processing and rheology system for optimized pasta quality.

We make the most of your raw materials.



# 2

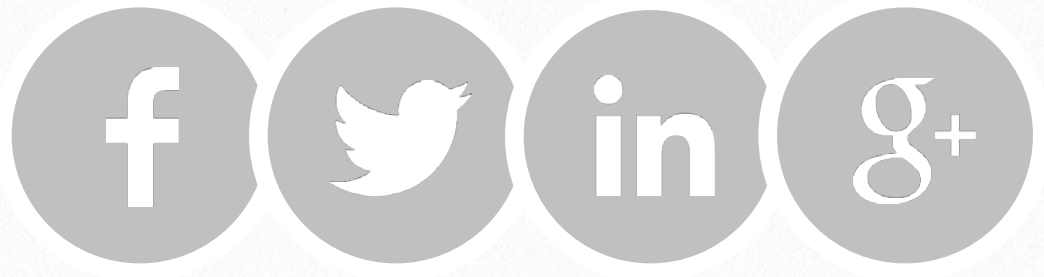

## Upvaluing of chestnut flour for gluten-free fresh pasta development

Davide Russo, Andrea Bresciani, Alessandra Marti  
University of Milan



The article illustrates the work carried out for the degree thesis of Davide Russo (University of Milan), who won one of the 2023 Pastaria Awards. The thesis evaluated the effect of the addition, at two different enrichment levels (15% and 25%), of two varieties of chestnut flour (Balestrera and Rossera) from the Val Seriana to a gluten-free formulation for the production of fresh pasta. In addition to the chemical and physical characterisation of the raw materials, the work involved the evaluation of the behaviour during cooking of the fresh pasta. The addition of chestnuts reduces optimal cooking time, water absorption capacity and consistency, as well as reducing losses during cooking.

## Introduction

Chestnuts (*Castanea sativa Mill.*) were once a primary energy source for rural and mountain populations in Italy. Following a period of production crisis related to social and phytopathological aspects, Chestnut growing has been attracting renewed interest in the food sector in recent decades. Their nutritional characteristics, including the presence of fibre and compounds with an antioxidant activity, make chestnuts an interesting ingredient for the development of food products. In addition, the absence of gluten makes them a useful resource for gluten-free formulations.

There are few works in scientific literature regarding the use of chestnut varieties as an ingredient for the production of pasta (regular or gluten-free), a product popular worldwide because it is practical, nutritious and appetizing, as well as for its ability to deliver bioactive compounds (Mercier et al., 2016; Wahanik et al., 2018).

The aim of this thesis project was to evaluate the technological performance of two varieties of chestnuts (Balestrera and Rossera) in the production of gluten-free foods (snacks and fresh pasta), at two enrichment levels (15 and 25%). The use of chestnut flour in gluten-free formulations would make it possible not only to improve the nutritional composition and sensory attributes of gluten-free products, but also to boost the use of hitherto underused crops. The two chestnut flours were first characterised from a chemical and physical point of view, and their rheological and functional properties were then evaluated. This was followed by the production and characterisation of two types of products: crackers and fresh pasta. In keeping with this call, only the results regarding the fresh pasta study will be presented here.

## Materials and methods

### Materials

The chestnut flours were supplied by the Misma Chestnut Growers' Association (Pradalunga, Bergamo), while the gluten-free mix (composed of corn starch, rice flour, guar flour and carboxymethyl cellulose) was supplied by Molino



TECHNOLOGY PERFORMANCE RELIABILITY

# CUOCITORE LINEARE LINEAR COOKER

100 - 1000 kg/h

Prodotti: paste ripiene, sfoglie con interfoglio, cannelloni  
For processing filled pasta, sheet with interleaf film, cannelloni



Larghezza nastro  
Belt width

750 - 1130 - 1500 mm

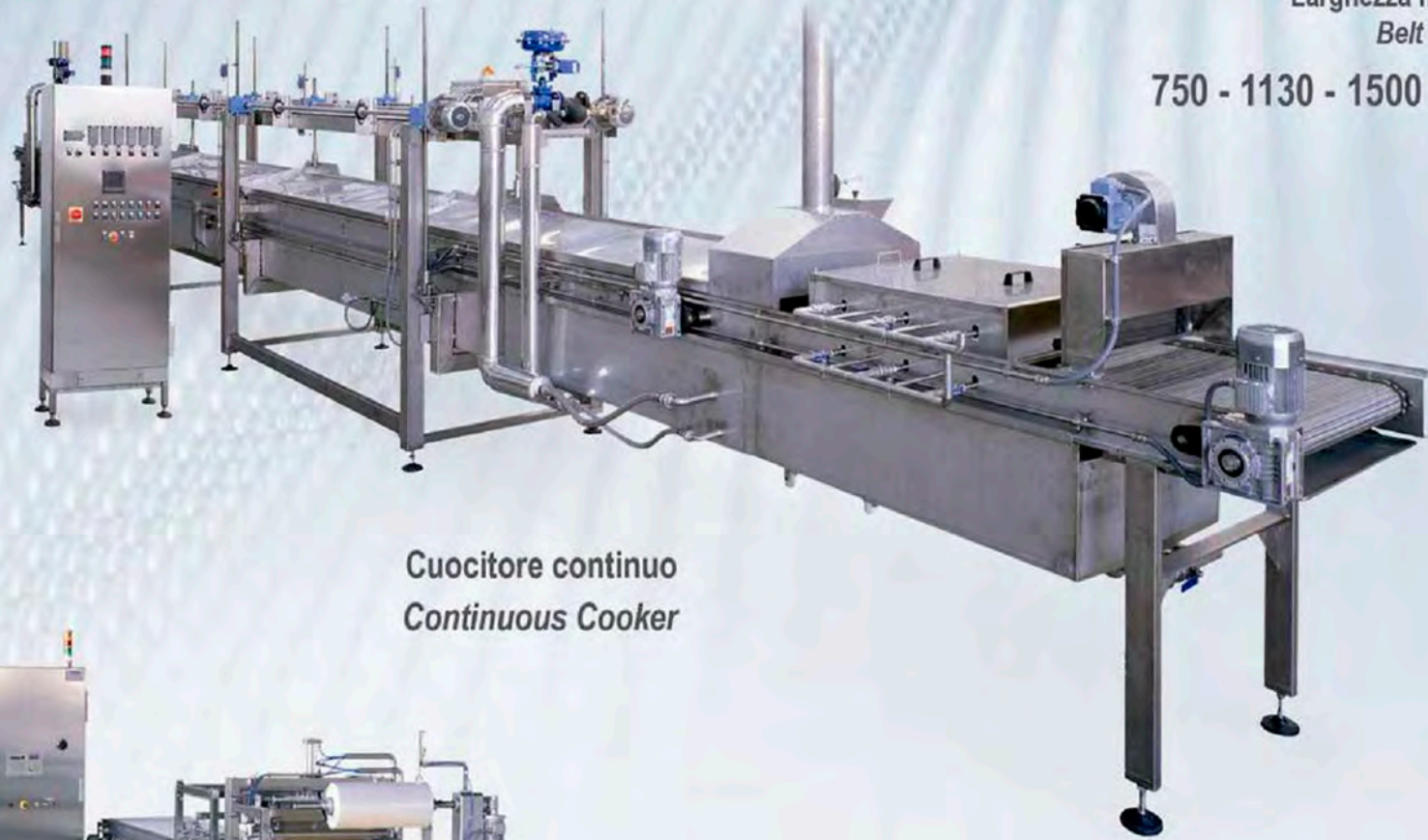

Cuocitore continuo  
Continuous Cooker



Interfoliatrice  
Line for sheet  
with interleaf film



Paste ripiene  
Filled pasta

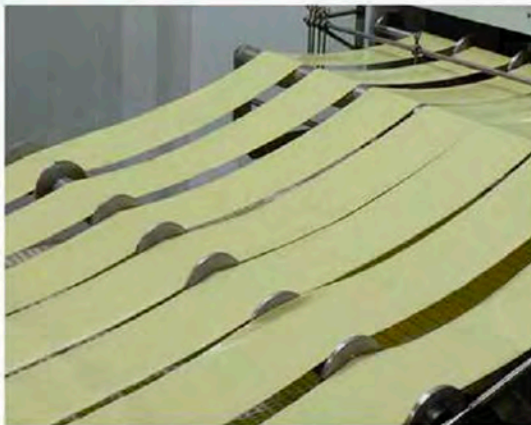
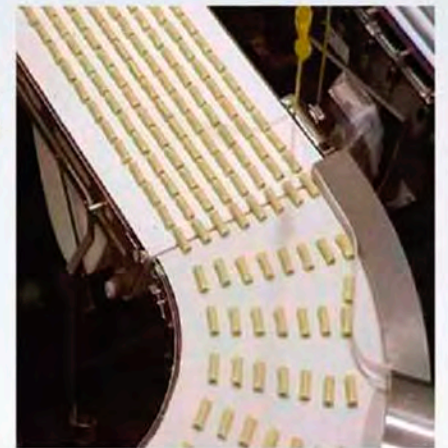

Sfoglie per Lasagne  
Lasagne sheets



Sforgia con interfoglio  
Sheets with interleaf film



Cannelloni

AZIENDA CON SISTEMA DI GESTIONE  
QUALITÀ CERTIFICATO DA  
TUV ITALIA S.r.l. secondo la norma  
UNI EN ISO 9001:2015

CAMPOSAMPIERO (PD) - ITALY - Via Martiri della Libertà, 6  
Tel. (+39) 049 9303590 - Fax: (+39) 049 5791258 - info@food-tech.it - [www.food-tech.it](http://www.food-tech.it)

Quaglia S.p.A. (Vighizzolo d'Este, Padua).

### **Characterisation of chestnut flour**

The humidity, protein, starch, ash, fibre and lipid content was determined using the official AACC methods (2001).

The gelatinisation and retrogradation properties of the starch were evaluated using a Micro Visco-Amylo-Graph (Brabender GmbH & Co. KG Duisburg, Germany), an instrument that measures variations in the viscosity of a suspension of starch/flour and water following the heating and cooling phases in controlled conditions. The test was conducted by mixing 12 g of chestnut flour in 100 ml of distilled water, correcting those values based on the humidity of the samples (base 14%). The operating conditions were as follows: temperature profile: 30 °C-95°C-30 °C; rotation speed: 250 revs/min; sensitivity: 300 cmg; temperature gradient: 7.5 °C/min.

The gelification properties were evaluated by preparing a gel, using the Micro Visco-Amylo-Graph, on a sample of 15 g chestnut flour in 100 ml distilled water (correction 14%), with the operating conditions indicated in the previous paragraph. At the end of the test, the gel was placed in two Petri dishes (diameter: 55 mm; height: 15 mm) stored at 4°C for 3 and 72 hours. At the analysis time

considered, the samples were subjected (after being left at room temperature for 30 mins) to a double compression test (TPA) using a TA.XT-plus texture analyser (Stable Micro Systems Ltd., Godalming, UK), equipped with a 100 N load cell and using a P/75 probe. The following parameters were used during the test: return distance: 30 mm; return speed: 10 mm/second; contact force: 5 gf.

### **Fresh pasta production**

The fresh pasta was produced using the gluten-free mix on its own or mixed with the two chestnut varieties at two enrichment levels (15% and 25%).

The fresh pasta was prepared by mixing water and flour (hydration 70%) in a KitchenAid mixer (model 5KSM150, Benton Harbor, MI, USA) to obtain a smooth, even dough. After resting for 15 minutes, the dough was divided into portions of approx. 50/60 g and laminated using the KSMPSA attachment of the mixer. The fettuccine ribbons were then produced, with the following characteristics: length 100 mm, width 13.5 mm and thickness 2 mm. Two different lots of pasta were produced for each formulation.

### **Characterisation of fresh pasta**

The optimal fresh pasta cooking time was

# ENJOY NEW FLAVOURS VEGAN FLAVOURINGS

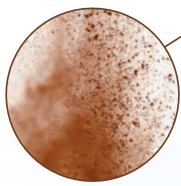

Natural organic  
and/or vegan flavours  
in liquid or powder form  
various cheese flavours



- ✓ GMO free
- ✓ Natural vegan
- ✓ Sustainable
- ✓ Biological
- ✓ Clean label
- ✓ Allergen free



NEW  
**FLAVOURS**<sup>®</sup>  
ITALIAN SENSATIONS

PRODUCERS OF FLAVOURINGS AND SEMI-FINISHED FOOD PRODUCTS



See you in Nuremberg  
BIOFACH Hall 5 • Stand 1-151  
13 - 16 February 2024

determined by a panel of 8 tasters. An evaluation was then conducted of the amount of water absorbed during cooking, losses during cooking and consistency, using the AACC 66-50.01 official method. Specifically, the structural characteristics of the fresh pasta were determined using a TA.XT-plus texture analyser (Stable Micro Systems Ltd., Godalming, UK), equipped with a 100 N load cell. For each production lot, 5 measurements were repeated on 5 fettuccine ribbons placed parallel to one another; the test was conducted after a set time of 5 minutes from the moment the pasta was drained.

### **Statistical analysis**

The significant differences between the two chestnut varieties were evaluated using a t-test (Statgraphics Plus 5.1; Statpoint Inc., Warrenton, VA, USA). The differences between the 5 fresh pasta formulations were evaluated using one-way analysis of variance and Tukey's HSD test (Statgraphics Plus 5.1; Statpoint Inc., Warrenton, VA, USA). To assess the effect of the variety and of the level of enrichment, two-way analysis of variance was used (Excel, Microsoft Building 99, Redmond, Washington, USA).

## **Results and discussion**

### **Chemical composition of the chestnut flours**

The chemical composition of the chestnut flours ([Table 1](#)) shows that the Balestrera variety has a higher protein and starch content than the Rossera variety, which has a higher fibre and total lipid content. No significant differences were found in ash content.

### **Gelatinisation and retrogradation properties of the starch**

The results presented in [Figure 1](#) and [Table 2](#) show significant differences between the two varieties of chestnuts.

Specifically, the Rossera variety has a gelatinisation start temperature of 50 °C and the Balestrera variety of 65 °C. As regards peak viscosity, the maximum swelling point of the starch granules, the values reached by the Balestrera sample were higher than those of the Rossera variety (201 BU and 166 BU respectively). This difference is probably due to the higher starch content of the Balestrera variety. Any differences in amylose/amylopectin distribution can be ruled out.

The two varieties also behaved differently during the 95°C temperature maintenance phase. The higher breakdown value

# MADE IN ITALY QUALITY, FROM MIXERS TO PASTEURIZERS

We study and realize  
**tailor-made** plants for **pasta  
manufacturers** all over the world.

Fresh pasta, stuffed or plain, dry,  
pre-cooked, sterilized or frozen:  
we have no limits for your  
custom-made production line.



Fresh stuffed pasta line  
400 kg/h

**SARF**

FOOD TECHNOLOGIES

[www.sarp.it](http://www.sarp.it)

**Table 1 CHEMICAL COMPOSITION OF THE TWO CHESTNUT VARIETIES**

	Balestrera	Rossera
<b>Moisture</b>	8.9 ± 0.1	8.6 ± 0.2
<b>Carbohydrates*</b>	71.2	69.5
<b>Total starch</b>	43.08 ± 1.0	38.47 ± 1.5
<b>Proteins</b>	6.9 ± 0.4	5.5 ± 0.4
<b>Lipids</b>	3.3 ± 0.2	4.5 ± 0.2
<b>Total fibre</b>	7.8 ± 0.5	10.1 ± 0.5
<b>Ash</b>	1.8 ± 0.1	1.8 ± 0.1

*All the figures are shown as an average ± standard deviation (g/100 g s.s.), with the exception of carbohydrates\*, calculated by difference*

recorded for the Balestrera variety could indicate greater stability of the starch granules during the cooking of the finished

product (Yildiz et al., 2013). There were also differences between the varieties in final viscosity after cooling, with higher

**Figure 1 GELATINISATION AND RETROGRADATION PROPERTIES OF CHESTNUT FLOURS**

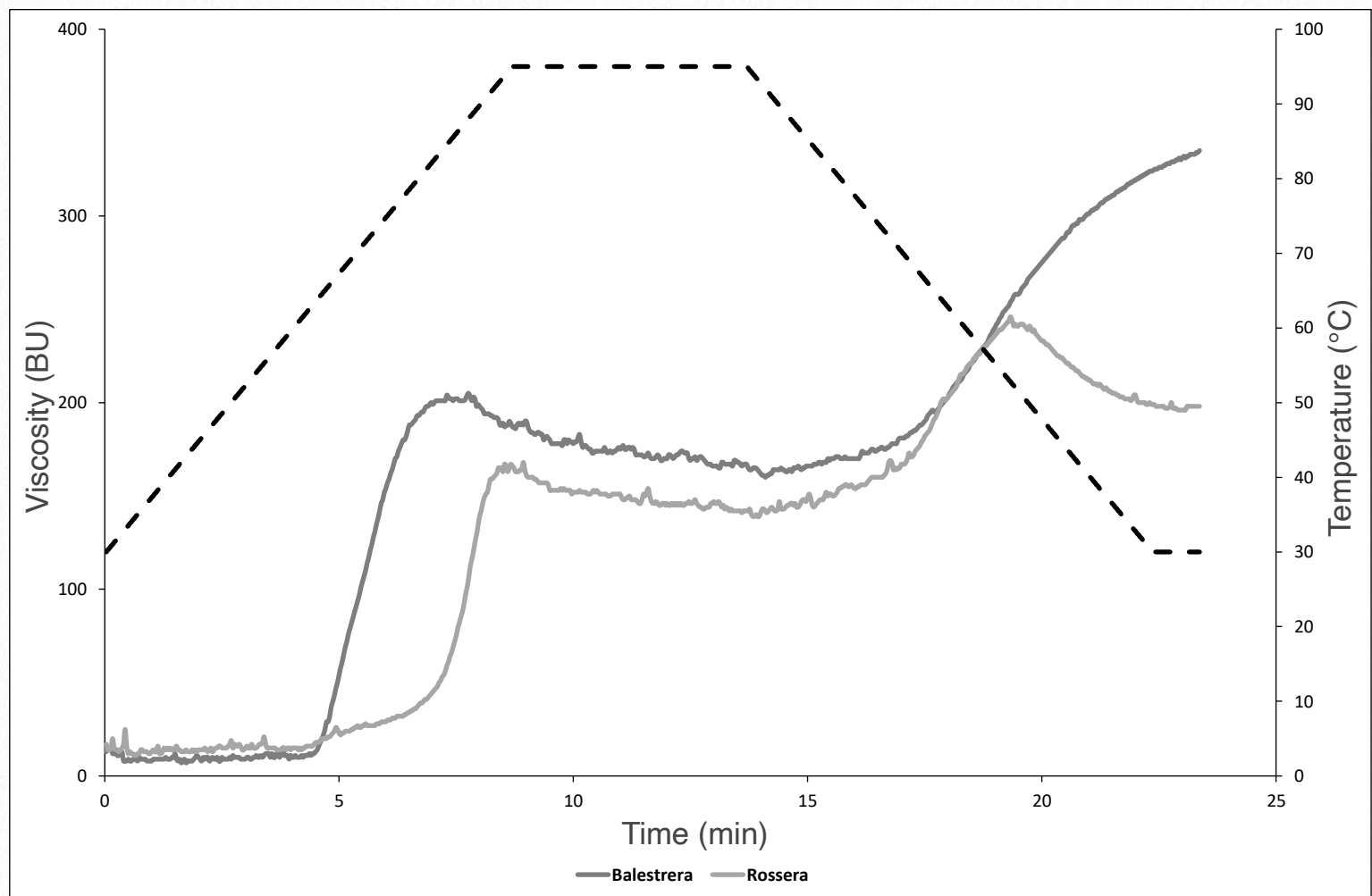

# PASTARIA HUB

[www.pastariahub.com](http://www.pastariahub.com)

TECHNOLOGIES  
INGREDIENTS  
SERVICES  
FOR PASTA  
MANUFACTURERS



technologies  
tecnologie  
tecnologías  
technologies



ingredients  
ingredienti  
ingredientes  
ingredientes



services  
servizi  
servicios  
services

**Table 2 DATA OBTAINED USING THE MICRO-VISCO-AMYLO-GRAPH**

	Balestrera	Rossera	Test t
<b>Gelatinisation start temperature (°C)</b>	65.25 ± 0.5	50.35 ± 6.3	ns
<b>Maximum viscosity (BU)</b>	201.00 ± 5.7	166.50 ± 2.1	p ≤ 0.05
<b>Peak temperature (°C)</b>	84.05 ± 4.6	94.85 ± 1.2	ns
<b>Breakdown (BU)</b>	39.00 ± 1.4	23.50 ± 3.5	p ≤ 0.05
<b>Final viscosity (BU)</b>	331.5 ± 4.9	198.50 ± 0.7	p ≤ 0.001
<b>Setback (UB)</b>	158.50 ± 2.1	54.00 ± 4.2	p ≤ 0.01

*The figures are shown as an average ± standard deviation. Statistical analysis conducted using t-test to evaluate significance between the two varieties (p ≤ 0.05); ns indicates no significance*

final and setback viscosity values for Balestrera than for Rossera. Specifically, setback viscosity indicates the level of reassembly of the amylose molecules released from the swollen starch granules during the cooling phase and the tendency to form a cohesive gel (Charles et al., 2004).

### Gelification properties

Gelification properties differ between the two varieties. Hardness - the maximum peak during the first compression phase - was significantly higher for the Balestrera variety after storing for 72 hours. This result appears consistent with the greater retrogradation tendency of this sample ([Figure 1](#)). As regards the other parameters

**Table 3 GEL TEXTURE PROPERTIES WITH STORAGE AT 4 °C**

	Balestrera (3 h)	Rossera (3 h)	Test t	Balestrera (72 h)	Rossera (72 h)	Test t
<b>Hardness (N)</b>	1.34 ± 0.1	0.85 ± 0.1	ns	2.96 ± 0.1	1.22 ± 0.0	p ≤ 0.05
<b>Adhesiveness (N/s)</b>	-93.67 ± 5.1	-112.5 ± 12.6	ns	-99.57 ± 8.8	-136.7 ± 16.9	ns
<b>Elasticity (%)</b>	0.81 ± 0.01	0.84 ± 0.01	ns	0.84 ± 0.03	0.88 ± 0.03	ns
<b>Cohesiveness (%)</b>	0.73 ± 0.01	0.75 ± 0.01	ns	0.76 ± 0.01	0.78 ± 0.06	ns

*The figures are shown as an average ± standard deviation. Statistical analysis conducted using t-test to evaluate significance between the two varieties (p ≤ 0.05); ns indicates no significance*



# We concretize *Your ideas*

Food processing line for typical regional pasta and filled pasta with a production capacity of 1200 Kg/h



Thanks to our experience and constant technological evolution we are able to engineer and build machines and systems tailored to the needs of each customer.

*Contact us, we will be happy to provide you with the right solution for you.*  
[www.facchinigroup.com](http://www.facchinigroup.com)

Figure 2 IMAGES OF THE FRESH PASTA BEFORE AND AFTER COOKING

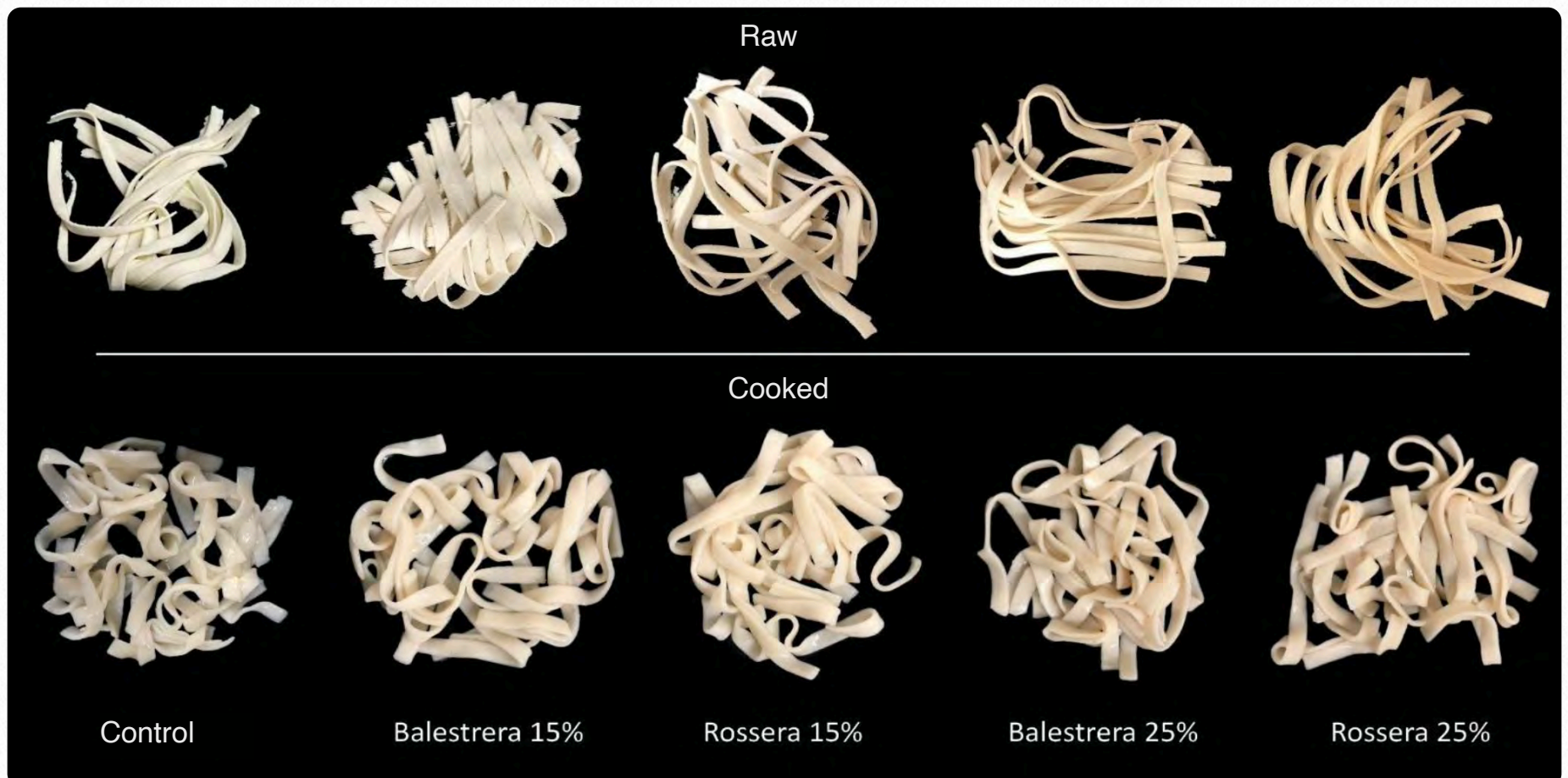

considered during the double compression test (adhesiveness, cohesiveness and elasticity), no significant differences were observed between the two varieties.

### Characterisation of fresh pasta

During the preparation of the gluten-free fresh pasta, it was observed that as the proportion of chestnut flour added increased, the time necessary for the development of a smooth dough decreased: compared to the control mix, which had an optimal dough-forming time of 8 minutes, the doughs with the addition of 15% and 25% chestnut flour had dough-forming times of 4.5 and 4 minutes respectively. This result could be due to the smaller amount of the base mix, containing pre-gelatinised flours/starches

and hydrocolloids, both of which are essential for the formation of a cohesive dough with gluten-free matrices: pre-gelatinised flours/starches and hydrocolloids are able to absorb water quickly at room temperature, but require a greater mechanical effort to obtain a smooth, even dough.

The images of the fresh pasta produced in this work, shown in [Figure 2](#), suggest that regardless of the variety and the percentage of the addition used, it is possible to produce a fresh pasta able to maintain its structures (and therefore to stay intact) during production and after cooking.

The quality during cooking of the fresh pasta, evaluated using official methods, is shown in [Table 4](#). The reformulation of

Siamo i principali produttori  
di pasta fresca e gnocchi  
in Italia, in Europa e nel Mondo  
**E questo non è casuale.**



**Associazione  
Produttori  
Pasta Fresca**

*Unisciti  
a Noi*

*"Il Presidente"  
Giovanni Rama*



Tra le nostre  
specialità da oggi  
**piatti pronti**



#### **I NOSTRI OBIETTIVI**

- Ottimizzare il mercato italiano ed inserirsi maggiormente in quello europeo con l'incentivazione e l'adozione anche nel mondo della pasta fresca dei **"piatti pronti o da cuocere a base di pasta fresca"**.
- Per tutelare pasta fresca e gnocchi, anche da un punto di vista legislativo nel loro progressivo inserimento nei mercati europei attraverso **ECFF** (European Chilled Food Federation).

#### **I NOSTRI SERVIZI**

- **Una guida anticipata sui trend di mercato e su quelli tecnici.**
- Un appoggio sicuro su problemi legislativi generali ed aziendali dove A.P.P.F. è tradizionalmente informata.
- Una gestione associativa concorde e non burocratizzata dove il Presidente e gli Associati hanno diritto ad un voto e la segreteria è sempre vicina.

#### **SOSTENITORI FORNITORI**

- IBERCHEM AROMAS S.R.L.
- MOLINI BONGIOVANNI S.P.A.
- MOLINI LOIZZO S.R.L.

- BAYERNLAND S.R.L.
- MANE ITALIA S.R.L.
- VALPAN S.R.L.
- PAN DI VICO S.R.L.

- PASTA TECHNOLOGIES GROUP SRL
- DI CURZIO S.R.L.
- IDA S.R.L.
- PARMOVO S.R.L.

- SALUMIFICIO LANZARINI S.R.L.
- NEW FLAVOURS S.R.L.
- CEREAL BROKER SARTIRANA CONSULTING S.R.L.



via Dei Borromeo, 16  
Padova - Italy  
T. +39 049 8760941

E. [info@appf.it](mailto:info@appf.it)  
W. [www.appf.it](http://www.appf.it)

**Table 4 CHARACTERISATION OF GLUTEN-FREE FRESH PASTA**

	Water absorption (%)	Cooking losses (g/100g)	Texture (N)	Work (gf/cm)
<b>Control</b>	65.81 ± 2.30c	5.28 ± 0.74b	5.9 ± 0.53c	51.36 ± 9.47d
<b>Balestrera 15%</b>	62.56 ± 0.85b	6.29 ± 0.31d	3.74 ± 0.31b	34.85 ± 5.49b
<b>Rossera 15%</b>	63.24 ± 1.02b	6.75 ± 0.96d	4.03 ± 0.60b	41.08 ± 8.02c
<b>Balestrera 25%</b>	53.38 ± 1.88a	4.51 ± 0.15a	3.06 ± 0.27a	28.97 ± 3.43a
<b>Rossera 25%</b>	54.14 ± 1.05a	4.93 ± 0.57ab	3.34 ± 0.62 a	32.26 ± 6.45ab
<b>Analysis of variance</b>				
<b>Variety</b>	ns	p ≤ 0.05	p ≤ 0.05	p ≤ 0.001
<b>Integration</b>	p ≤ 0.001	p ≤ 0.001	p ≤ 0.001	p ≤ 0.001
<b>Interaction</b>	ns	ns	ns	ns

fresh pasta with chestnut flour resulted in a significant reduction in the amount of water absorbed, the consistency and the effort required to cut the cooked product. Specifically, the “variety” variable proved significant in terms of consistency, work and losses during cooking, with the Balestrera variety able to produce a fresh pasta characterised by less significant losses during cooking, and greater consistency and workability than pasta prepared using the Rossera variety. The enrichment level also had a significant impact on the indexes considered. Specifically, higher chestnut flour content resulted in lower water absorption, losses during cooking, consistency and workability. Finally, the variety interaction of variety by enrichment level did not prove significant.

During the cooking of the fresh pasta, an increase was observed in the loss of solids compared to the control sample, as also demonstrated by Littardi et al., (2020) for wheat-based pasta; the values shown in the table show that both the pastas enriched with 15% chestnut flour lost more solids during cooking than the pasta produced with higher enrichment levels (25%); these results can be attributed to the different optimal cooking times of the two pastas, which are 3.5 minutes and 1.5 minutes respectively. The cooking times of the experimental samples are in line with the values shown in previous works, which found that optimal cooking times decreased as the chestnut flour enrichment levels rose (Oniszczyk et al., 2019; Kosovic et al., 2016).

# FIERA PASTARIA

INTERNATIONAL PASTA FACTORY  
SUPPLIERS TRADE FAIR **& FESTIVAL**

**A single trade fair for  
all pasta factory suppliers.  
Together at the eighth  
Pastaria Festival.**

Come to Fiera Pastaria and visit the stands of **international suppliers** of ingredients, flavourings, semi-finished products, machinery, equipment, accessories and services for the **production of pasta**.

Join us to **take part** in the myriad meetings, seminars, presentations and round tables on pasta that make up the **Pastaria Festival** programme.

To book an exhibition space: **T. +39 (0)521 1564934**  
For information: **info@pastaria.it**

**STAZIONE LEOPOLDA**  
**FLORENCE, 20-21 MAY 2024**  
**SAVE THE DATE**

Organised by

**Pastaria**

**PASTARIA  
FESTIVAL**  
Sharing know-how on pasta manufacturing

With the collaboration of

**abimapi**  
COM.BR

**APPAFRE**  
Associazione produttori pasta fresca  
della piccola e media impresa

**apff**  
Associazione  
Produttori  
Pasta Fresca

**IPO**  
INTERNATIONAL  
PASTA  
ORGANISATION

**UN.A.F.P.A.**  
Unione Nazionale  
Associazioni Produttori  
Pasta Fresca

**Unione  
Italiana  
Food**  
qualità, gusto e piacere

**UIFRA**

## Conclusions

The addition of chestnut flour appears promising for the production of gluten-free fresh pasta. The compositional and nutritional characteristics and the wealth of biocomponents chestnuts contain provide ample justification for the new role the fruit is taking on in the modern diet. The comparison between the two chestnut varieties grown in Val Seriana (Bergamo)—Balestrera and Rossera—shows that despite the differences in the chemical and physical composition of the two, there are no particular differences in their functional and rheological properties. Differences emerged with regard to the gelatinisation and retrogradation properties of the starch and the gel formation properties. The characteristics of the Balestrera and Rossera varieties make them suitable for the production of fresh pasta, even with enrichment levels of 25%. Future studies might consider the characteristics of other cultivars, with a view to identifying those best suited to the processes of transformation into grain-based products and the use of pasta making processes involving heat treatments such as desiccation or pasteurisation.

### GET THE MOST OUT OF THE PASTARIA NETWORK.

#### ✓ Read the **Digital Magazine**

Published on odd months. Download it from [pastaria.it](http://pastaria.it) or read it using the App.

#### ✓ Read the **Paper Magazine**

To receive future issues please register on [pastaria.it](http://pastaria.it) and activate a free subscription  
Published on even months

#### ✓ Read the articles published on **Pastaria.it**

Log on daily to discover what's new in the sector.

#### ✓ Follow and share what we do on our **social media channels**

Facebook: <https://www.facebook.com/PastariaMagazine/>

Twitter: <https://twitter.com/rivistapastaria>

#### ✓ Take part in **Pastaria Festival**

#### ✓ Install the **Free App**

For smartphones and tablets, iOS and Android

*And there's more:*

✓ Find and request offers for machines, ingredients and services on **[pastariahub.com](http://pastariahub.com)**

## Acknowledgements

Thanks go to the Misma Chestnut Growers' Association and the project "Research and innovation network on food and nutrition Sustainability, Safety and Security (ONFoods)", funded within the framework of the National Recovery and Resilience Plan (PNRR), Mission 4 Component 2 Investments 1.3-Tender notice no. 341 of 15 March 2022 of the Ministry of Universities and Research, funded by the European Union-NextGenerationEU, Project code PE00000003, Granting Decree no. 1550 of 11 October 2022, CUP D93C22000890001.

## Bibliography

*AACC Approved Methods of Analysis (2001).*

Cereals & Grains Association, St. Paul, MN, U.S.A.

Charles, A. L., Chang, Y. H., Ko, W. C., Sriroth, K., & Huang, T. C. (2004). *Some physical and chemical properties of starch isolates of cassava genotypes*. *Starch-Stärke*, 56(9), 413-418.

Kosovlć, I., JuKlć, M., JozInovlć, A., AčKAr, Đ., & Komlenić, D. K. (2016). *Influence of chestnut flour addition on quality characteristics of pasta made on extruder and minipress*. *Czech Journal of Food Sciences*, 34(2), 166-172.

Littardi, P., Paciulli, M., Carini, E., Rinaldi, M., Rodolfi, M., & Chiavaro, E. (2020). *Quality evaluation of chestnut flour addition on fresh pasta*. *LWT*, 126, 109303.

Mercier, S., Moresoli, C., Mondor, M., Villeneuve, S.,

& Marcos, B. (2016). *A meta-analysis of enriched pasta: What are the effects of enrichment and process specifications on the quality attributes of pasta?*. *Comprehensive Reviews in Food Science and Food Safety*, 15(4), 685-704.

Oniszczyk, A., Widelska, G., Wójtowicz, A., Oniszczyk, T., Wojtunik-Kulesza, K., Dib, A., & Matwijczuk, A. (2019). *Content of phenolic compounds and antioxidant activity of new gluten-free pasta with the addition of chestnut flour*. *Molecules*, 24(14), 2623.

Wahanik, A. L., Chang, Y. K., & Clerici, M. T. P. S. (2018). *How to make pastas healthier?* *Food Reviews International*, 34(1), 52-69.

Yildiz, Ö., Yurt, B., Baştürk, A., Toker, Ö. S., Yilmaz, M. T., Karaman, S., & Dağlıoğlu, O. (2013). *Pasting properties, texture profile and stress-relaxation behavior of wheat starch/dietary fiber systems*. *Food Research International*, 53(1), 278-290.

# SIDE

Machines and plants for food industry

## PASTEURIZING, PRE-DRYING AND FREEZING PLANT FOR STUFFED PASTA

Production capacity: 1000 Kg/h



Nowadays, the needs in pasta factories are ever greater: production plants must be more compact, easily washable and highly efficient.

**SIDE** responds by building innovative machinery from time to time, acting on the basis of specific customer requests.

The combined pasteurizing/drying machine and the cooling/freezing spiral are valid examples, so much so that they now represent two leading elements of the wide range available.

[www.sideprotech.com](http://www.sideprotech.com)

Viale Giovanni Falcone, 16 - 31037 Castione di Loria (TV) - Italy

Tel. +39 0423 078 217 - E-mail: [info@sideprotech.com](mailto:info@sideprotech.com) - Site: [www.sideprotech.com](http://www.sideprotech.com)

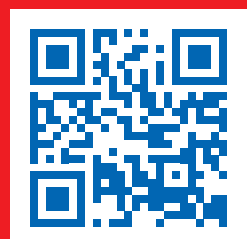



3



# Commodity price observatory 1/2024

Pastaria Centre for Economic Research



Pastaria's four-monthly feature on the prices of the main raw materials used by pasta manufacturers.

The scenario outlined by ISTAT in “Prospects for the Italian economy in 2023-2024” suggests the likelihood of a further fall in inflation. This is based on reduction forecast in energy prices and other imported materials, already under way, and a gradual relaxation in the hitherto restrictive monetary policies implemented on several occasions by the European Central Bank (ECB). These circumstances are expected to lead to a slight recovery of trade with foreign countries, and to a more decisive rise in domestic demand, driven by private consumers (+1.4% in 2023 and +1% in 2024), who can now benefit from a gradual (although partial) recovery of household purchasing power and consolidation of employment levels.

Investment, in contrast, is expected to witness a distinct slowdown compared to the preceding two-year period, with a 0.6% growth rate forecast for both years. The only driving factor is the gradual implementation of the National Recovery and Resilience Plan (PNRR), which is still, however, set to end in 2026.

It should also be considered that, in the wider international context, the most recent conflict in the Middle East has introduced a new factor of risk (and uncertainty) that has the potential to upset raw materials markets, which in recent years have already had to cope with an extraordinary series of impacts as a result of the domino effect triggered by the sharp rise in the prices of energy products. Before the start of the war between Israel and Palestine, the squeeze on oil supplies on the part of OPEC+ producers had pushed up crude oil prices, resulting in a rise in inflation across the whole energy sector. As tension lessened, prices gradually fell back, starting from October, and are now more stable, foreshadowing more moderate rises in the other commodities.

Another aspect to consider is the growth of the global economy, which will probably be weaker than had been expected. According to the World Bank, these characteristics are likely to result in disinflation with regard to raw materials, including agricultural materials and foodstuffs.

On the other hand, offer conditions across all soft commodities and basic food products have improved on the whole, with the exception of a

# ROD FORMING MACHINE FOR DOUBLE-SHEET RAVIOLI

Model:

**RA 250**

Production capacity:  
from **200 kg/h** up to **350 kg/h**

Double sheet ravioli machine with interchangeable moulds and rod filling injection system, designed to work with soft fillings. Machine equipped with a double calibrator for fine adjustment of the pasta sheet. Built entirely in AISI 304 stainless steel and Industry 4.0 compatible



Fresh pasta machines  
Pasta factory equipment  
[www.castiglioninedo.it](http://www.castiglioninedo.it)



**PRICES AND TRENDS OF CERTAIN FOOD RAW MATERIALS (DECEMBER 2023)**

	Price (€/ton)	Monthly variation	Annual variation	Forecast
<b>National fine common wheat</b>	247.5	0.2%	-28.9%	▼
<b>Fine durum wheat from North Italy</b>	372.5	0%	-20.8%	▼
<b>00 type common wheat flour</b>	575	0.9%	-21.2%	=
<b>Semolina above min. leg. req.</b>	702.5	0%	-14.3%	=
<b>Eggs M</b>	17.85	1.4%	-6.3%	▼
<b>Pork hams for Prosciutto 12 kg and over</b>	5.08	-0.4%	0.8%	▼
<b>Beef – veal meat half-carcass, prime quality</b>	7.07	1.6%	2.9%	=
<b>Raw milk</b>	55.16	12.6%	-8.1%	=
<b>Centrifuged butter</b>	5.52	3.8%	-1.4%	▼
<b>Grana Padano aged for 9 months or more</b>	8.81	0.7%	-6.6%	▼
<b>Extra virgin olive oil</b>	9.1	7.9%	49.2%	=

*Source: Centro Studi Economici Pastaria elaboration based on various data sources. Grain, flours and semolina: Granaria, Bologna; Eggs: CCIAA, Forlì; Pork and beef: Commodity Exchange, Modena; Milk, butter and Grana Padano: Commodity Market, Milan; Olive oil: CCIAA, Bari.*



LEBEN INGREDIENTS

THE  
*Nature inside*

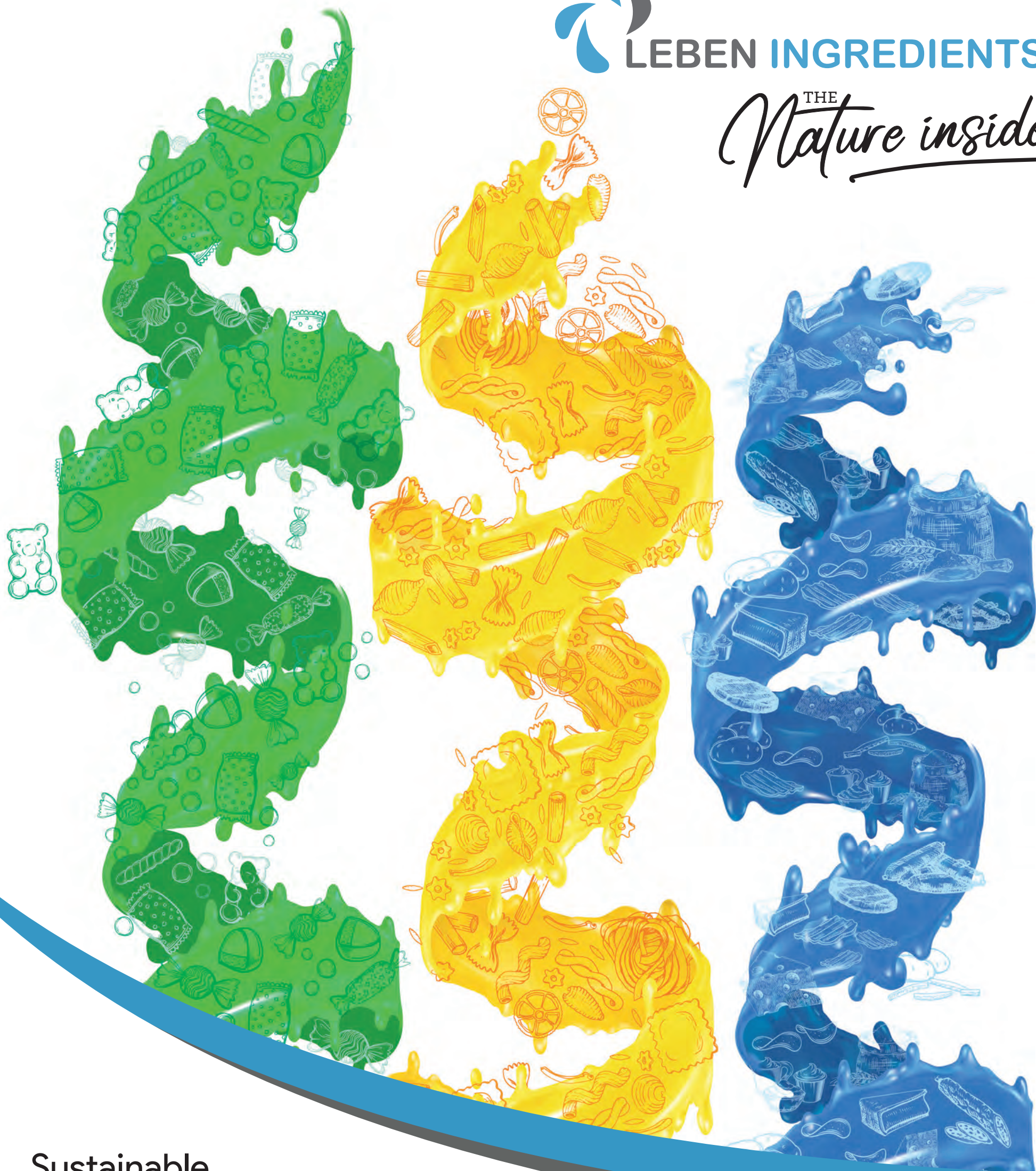

Sustainable  
*raw materials* from renewable sources.

LEBEN INGREDIENTS

via Dante Alighieri, 43 - Lissone (MB) ITALY - Tel. +39 039 9405130

[www.lebeningredients.it](http://www.lebeningredients.it)

**PRICE MONITORING**

FAO Food Price Index	Price (2014-2016=100)	Monthly variation	Annual variation	Forecast
	120.4	0%	-10.6%	▼
Hard Red Winter US Gulf port	Price (USD/ton)	Monthly variation	Annual variation	Forecast
	283.55	-4.9%	-32.9%	▼
Mais, U.S. No. 2 Yellow FOB US Gulf port	Price (USD/ton)	Monthly variation	Annual variation	Forecast
	211.26	-8.4%	-34.2%	▼

*Fao Food Price Index, Hard Red Winter, Mais: November 2023*

number of shortages due to contingent production deficits. A number of potential factors of imbalance remain, associated for the most part with the geopolitical risk posed by the two on-going wars, which could result in renewed, largely speculative price volatility. Save for modest shifts, agricultural produce prices have remained relatively stable, based on figures from the last twelve months, confirming a drop compared to the levels of one year ago. There has been a sharper fall in the prices of food products, in a situation in which a number of factors that pushed prices up—such as the non-renewal of the Black Sea Grain Initiative, the Indian ban on the export of non-basmati rice and the intensification of weather and climate phenomena caused by El Niño—were offset by an improvement in supply prospects, in particular for maize, soybeans and wheat.

According to the World Bank projections, following a 7% drop in 2023, first trading agricultural prices are expected to fall by a further 2% in the two-year period, given that stocks are expected to be sufficient to compensate for any negative events such as decreases in production and adverse weather conditions. As regards grains and seed oils, the stock-to-use ratio—an indicator constantly monitored by markets—is falling further, but remains at a “comfortable” level, according to operators, well above the critical threshold of 20% that marked the 10-year-period 2005-2014. Following the 11% reduction experienced over the last 12 months, grain prices are expected to fall further, around 3% in 2024 and 5% the following year. On the durum wheat market in particular, the annual price gap stands at around 20%, although the world harvest—



# APPAFRE

Associazione produttori pasta fresca  
della piccola e media impresa



## INSIEME PER ESSERE PIÙ FORTI!

**A.P.PA.FRE.** associa imprenditori della piccola e media impresa, produttori di pasta fresca e gnocchi, per meglio tutelare una categoria di produttori, troppo spesso dimenticati. I nostri associati, sono riconosciuti dalle istituzioni e dal mercato, come categoria di pastai che rappresentano la vera tipicità e la migliore tradizione culinaria italiana. Fiore all'occhiello del made in Italy, riconosciuta e apprezzata anche all'estero.

**A.P.PA.FRE.** si caratterizza per la capacità di offrire gratuitamente ai propri associati, qualsiasi consulenza di carattere tecnico e normativo, oltre alla divulgazione di informazioni su iniziative legislative.

Per info e/o contatti:

Virna Soncin (segretario) - Cell. 348.6593130

### SOCI SOSTENITORI / FORNITORI

Ecochimica S.r.l. Casalzuigno (VA)  
PRC Impianti S.r.l. Borgo Ticino (NO)  
Molino Grassi S.p.a. Fraore (PR)  
IPAM S.r.l. Zibello (PR)  
Flavourland S.r.l. Pero (MI)  
G&Partners S.A. Taverne (CH)

Italgi S.r.l. Carasco (GE)  
Milani Foods S.r.l. Verona (VR)  
Parmovo S.r.l. Colorno (PR)  
Pastaria - Kinski Editori Parma (PR)  
ePublic S.r.l. Novara (NO)  
Vercelli S.p.a. Formigliana (VC)



A.P.Pa.Fre. Sede operativa c/o CNA PIEMONTE NORD

Viale Dante Alighieri 37 - 28100 Novara (NO)

Tel. 0321.399564/5 - Fax 0321.398488

info@appafre.it - www.appafre.it

Piemonte Nord

# PASTARIA HUB

[www.pastariahub.com](http://www.pastariahub.com)

TECHNOLOGIES  
INGREDIENTS  
SERVICES  
FOR PASTA  
MANUFACTURERS

estimated by the International Grains Council (IGC) at around 31.4 million tonnes—was down 9.1% compared to the previous harvest as a result of the severe drought in Canada (-30%). In Europe, forecasts confirm a production of approx. 7 million tonnes (-5.5%), but mass exports planned by Turkey, at competitive prices, in addition to the pressure of other suppliers in the Black Sea Region, should be able to contain the effects on prices. Current prices for maize and soft wheat also reflect this downward trend on the part of operators, with European markets remaining subject to strong pressure from Ukrainian grains and the competitive pressure of Russia, once again the world's top exporter of wheat. The massive presence of Ukraine on European markets also explains the bearish dynamics observed with regard to poultry, egg and sugar prices. Olive oil is

one of the few agrifood products bucking the trend. The tensions caused by another year of falling production in Spain, the world's largest producer and exporter of olive oil, have already pushed prices of extra virgin oils up to record levels of over €9 /kilo, leading to a repeat of last year's inflationary scenario. As regards dairy products, the drop in profitability on European dairy farms due to high production costs and the restrictions imposed for compliance with environmental regulations are further limiting production capacity in the EU. No significant swings in prices are expected over the coming months. A rise is possible, on the other hand, in palm oil prices, which fell by more than 10% in 2023 in view of a drop in global production due to the dry climate caused by El Nino, and a rise in demand, also for the production of biodiesel.





# MACCHINE ED IMPIANTI PER PASTA



# 4

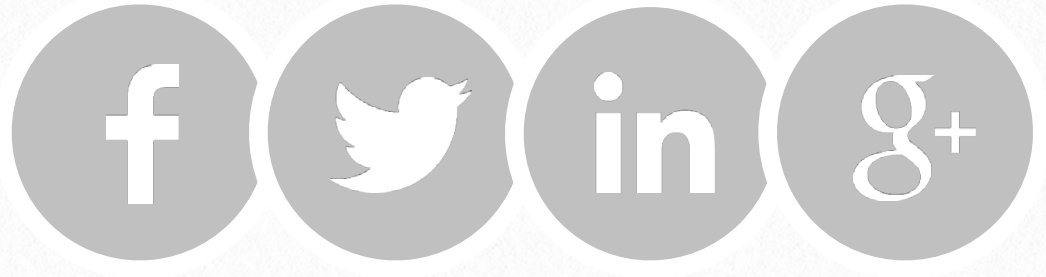

## Wheat, the main food source of the human race

**Luigi Cattivelli**  
Crea Genomics and Bioinformatics  
Research Centre (Fiorenzuola d'Arda)



Processed into semolina or flour, it is the main ingredient in pasta. We are going to talk about wheat, describing in this paper its nutritional and agronomic aspects, in its myriad varieties, both ancient and modern.

# Wheat

By “wheat” we mean around 20 cultivated or wild species and subspecies, closely related to each other and belonging to the genus *Triticum*. But if we limit ourselves to cultivated wheats used for human consumption, we have:

- monocot (*T. monococcum*) which was the first wheat cultivated by Neolithic man around 12,000 years ago, in the so-called fertile half-moon when agriculture was born;
- emmer (*T. turgidum* subspecies *dicoccum*), which was cultivated in the time of the ancient Romans (the Latin word “*farina*” (flour) comes from the Latin word “*far*” (emmer));
- durum wheat (*T. turgidum* subspecies *durum*) which replaced emmer as of the end of the Roman Empire;
- *T. turgidum* subspecies *turanicum* (known commercially as kamut® or “khorasan wheat”), a subspecies very similar to durum wheat that evolved in the area of present-day Iran;
- spelt (*T. spelta*);
- soft wheat (*T. aestivum*).

Last but not least, it is important to know that some cultivated forms of wheat have dressed seeds, i.e. at harvest time the seeds appear wrapped in glumes that have to be removed (husking) before

milling to produce flour; monocot, emmer and spelt are dressed wheats. Types of wheat in which the glumes spontaneously separate from the seed at harvest are called naked seeds; durum wheat, soft wheat and *T. turanicum* are examples of naked seeds.

Overall, we have six types of cultivated wheat, three of which are dressed and three naked, as well as other types of wheat that are either wild or no longer cultivated.

For each of the cultivated species, we can find ancient local populations (wheat varieties that were cultivated in Italy until the early 1900s), so-called ancient varieties (wheat selected by researchers from the early 1900s until the 1960s) and modern varieties (from the 1960s onwards).

## Why choose modern wheat?

For the past 10,000 years, man has constantly selected better grains, first on a totally empirical basis and then, since the early 1900s, by putting genetic and, more recently, genomic knowledge to good use. On empirical grounds, man has selected the cultivated forms by differentiating them from the wild ones (in the latter case, the seeds fall from the ear once ripe, a characteristic that is extremely useful for



each pasta maker  
has its own semolina  
from the field to the table  
ours is **tailor made**  
and caters to the supply chain  
of each pasta factory



[molinidevita.it](http://molinidevita.it)  
[info@molinidevita.it](mailto:info@molinidevita.it)  
+39 0881 558556

Headquarter:  
Casalvecchio di Puglia  
SP 11 / Km14 - 71030 (FG) Italy

the dissemination of the offspring seeds but which renders seed collection arduous), subsequently preferring the naked forms, particularly the varieties with large seeds, for the sake of convenience, since the naked seeds do not have to be husked. In the last 100 years, great strides have been made in the genetic improvement of wheat, leading to the selection of modern wheats through a succession of new varieties.

Work on the genetic improvement of wheat was initiated in the early 1900s by Nazareno Strampelli (1866-1942). His efforts led to the creation of dozens of soft and durum wheat varieties, some of which were very successful internationally, such as Senatore Cappelli durum wheat (1915) or Mentana (1923) and San Pastore (1931) soft wheat. In the period prior to World War II, the adoption of the varieties selected by Strampelli brought about significant increases in production. After Strampelli's pioneering work, Norman Borlaug, a geneticist working at CIMMYT (the International Maize and Wheat Improvement Center in Mexico) selected modern wheat varieties that lifted many countries in Central and South America and Asia out of hunger, a varietal renewal that has been referred to as the "green revolution".

The underlying reason for all the genetic improvement work was, and still is, the need to increase production per unit of surface area in a sustainable context; it is important to remember that without the increases in production over the last century, there would be not be enough food for everyone today. Increased agricultural production can be achieved through the use of improved cultivation techniques (including the use of fertilisers and crop protection products) or through the selection of genetically more productive plants. In the case of wheat, the huge increase in production in Italy (the yield per hectare has at least tripled since the early 1900s) and in the rest of the world is at least 50% attributable to genetic improvement, and in the decades to come, the role of genetic improvement will be even greater.

Genetic improvement has impacted various characteristics. Modern wheat is much shorter than ancient wheat and is therefore resistant to lodging (the loss of the upright position of the plant during the ripening phase, which makes harvesting very difficult, limits production and impairs quality). It also benefits from the use of fertilisers. Wheat crops in the early 1900s were over 150 cm high, while the height of today's wheat is around 70-80 cm.



1873 - 2023

*All over the world from*

**150** *years*



**[WWW.CAPITANIO.IT](http://WWW.CAPITANIO.IT)**

**CAPITANIO CAMILLO & C. S.a.s.**

**COMO HEADQUARTER:** via Bisbino 1 | 22070 Grandate (CO) | Tel. +39 031564621 | Fax + 39 031564631 | [info@capitanio.it](mailto:info@capitanio.it)

**TORRE ANNUNZIATA BRANCH:** via Mortelleto 1 | 80058 Torre Annunziata (NA) | Tel. +39 0818611436 | Fax + 39 0818621405 | [marco@capitanio.it](mailto:marco@capitanio.it)

Plants more suited to the Italian environment have been selected through the introduction of earliness factors that enable wheat to ripen before the summer heat, thereby avoiding the shrivelling of the caryopses due to a combination of high temperatures and dryness. Modern wheat is more resistant to diseases, especially fungal ones, a characteristic that enables a reduction in the use of phytopharmaceuticals and improves the healthiness of the product and the sustainability of the crop. For example, there have been recent issues of soft wheat varieties with a higher resistance to ear fusarium, a serious disease that causes the accumulation of mycotoxins that are a major risk factor for human health. Under the same agronomic conditions, modern wheat has a lower protein and gluten content than ancient wheat, but its gluten has much better technological characteristics that make bread softer and maintain the al dente texture of pasta.

## **Wheat composition and nutritional value**

Wheat has been the basis of the Western world's diet for around 10,000 years. Its extraordinary success has been due to its technological and nutritional

characteristics. Wheat seeds are rich in starch, protein, fibre, minerals, vitamins and antioxidant compounds, but the distribution of these nutrients within the seed is not homogeneous. Starch and protein are concentrated in the endosperm (the white part of the seed), while fibre, vitamins (A, B1, E, K), polyunsaturated fatty acids, minerals (calcium, phosphorus, magnesium, iron, zinc, copper) and bioactive compounds are concentrated in the aleurone layer (the layer of cells that surrounds the endosperm), in the outer tegument and germ, so only a daily consumption of wholegrain products guarantees the intake of all the nutrients present in wheat seeds.

Fibre is a nutritionally important component due to its role in regulating various physiological functions of the human body, in particular the proper functioning of the gastrointestinal tract. Whole-grain products are also distinguished by the presence of bioactive compounds: these are chemically heterogeneous compounds with an antioxidant and/or anti-inflammatory action, which can positively influence health by contributing to the prevention or treatment of various chronic-degenerative diseases.

Starch is the main component of wheat caryopses and flour, which makes



**IFT** ITALIAN  
FOOD  
TECHNOLOGY

# PLASTIC FRAME FOR DRYING PASTA Standard CE

*Successfully used in  
prestigious pasta maker  
in Italy and worldwid*

## Models:

TPP35: mm 1200x600xh35

TPP54: mm 1200x600xh54

TPP70: mm 1200x600xh70

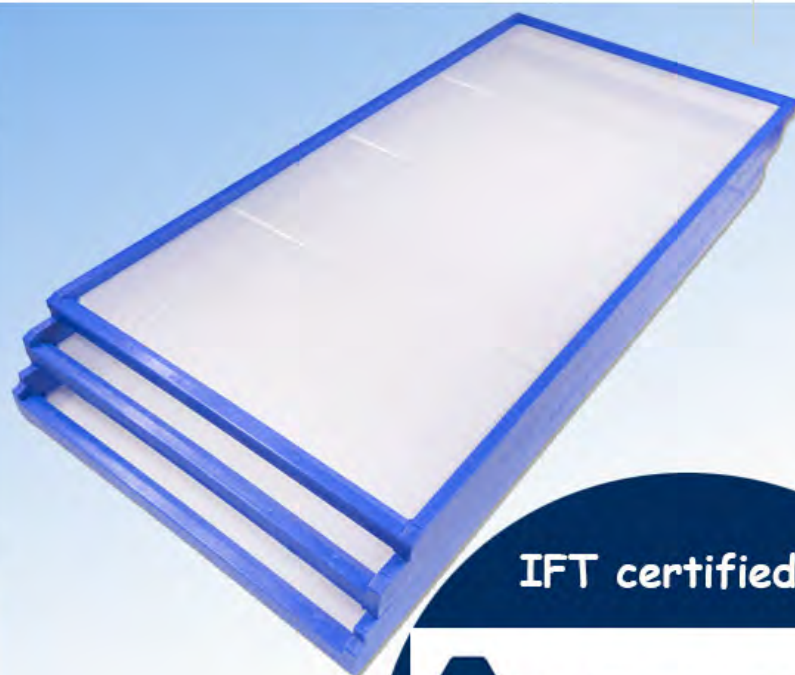

IFT certified

 **IFS**  
Broker



wheat-based foods predominantly high-energy products. In a balanced diet, 45-60% of the calories in the daily ration should come from carbohydrates, at least  $\frac{3}{4}$  of which should be in the form of complex carbohydrates (starch). In light of the most recent dietary recommendations, it is clear that wheat products are an excellent source of carbohydrates, which are essential for effective human nutrition. Protein plays a primary role in the nutritional success of wheat. Many of the organoleptic characteristics of flour-based foods, such as the porosity of biscuits, the softness of bread and even the tenacity of al dente pasta, are due to the particular protein composition of wheat.

Approximately 80% of the proteins contained in a wheat seed are gliadins and glutenins, two families of proteins present in the endosperm of the seed. When gliadins and glutenins are mixed together in the presence of water, they generate a protein mesh called gluten. Gluten is a matrix with unique properties: it is both elastic and extensible and these characteristics vary depending on the specific composition of the gliadin and glutenin families present. These properties explain the ability of a dough made with flour and water to rise, trapping the carbon dioxide produced in the leavening process and generating a more or less soft

product, but also its ability to trap starch granules and retain them when cooking the pasta dough in boiling water, producing al dente pasta.

## **Coeliac disease and non-coeliac gluten sensitivity**

Gluten proteins are also responsible for the intolerances and allergies. Coeliac disease is an intestinal disorder caused by a permanent intolerance to gluten, which appears in genetically-predisposed individuals. Coeliac disease is the most widespread food intolerance in Italy and is estimated to affect around 1% of the population. The only treatment available for coeliac disease is the total exclusion of gluten from the diet for life.

Notwithstanding the limitations of a gluten-free diet on the quality of social life, it is indispensable for the remission of the symptoms associated with coeliac disease and for preventing serious complications in sufferers. The gluten-free diet is, therefore, a therapy that consists of foods that are naturally free from this protein (fruit, vegetables, pulses, meat, fish, potatoes and other tubers and certain cereals) and foods specially formulated for coeliacs with “deglutinated” (gluten-free) raw materials. The main cereals allowed for coeliacs are rice, maize, sorghum and

BRAZILIAN  
BISCUITS, PASTA  
AND INDUSTRIALIZED  
BREADS & CAKES  
ASSOCIATION

**TOGETHER WE  
ARE STRONGER**

We represents more than **40 billion** in sales per year, **3.5 million** tons of products consumed and **158k tons** of brazilian Biscuits, Pasta and Industrialized Breads & Cakes around the World.



Brazilian Manufacturers Association of Biscuits,  
Pasta and Industrialized Breads & Cakes

**BRAZIL IS IN THE TOP 10  
IN THE BAKERY INDUSTRY**

3<sup>rd</sup> place for **biscuits** in the world;  
3<sup>rd</sup> place in the dried **pasta** in the world;  
9<sup>th</sup> package **bread** in the world.

Follow us on:





Luigi Cattivelli at the round table on *Pasta: scientific truth versus fake news* held at the 2023 edition of the Pastaria Festival

millet, in addition to pseudocereals (amaranth, buckwheat and quinoa). These seeds do not contain gliadins and glutenins, and are therefore gluten-free. In contrast, all types of wheat (including monocots, emmer and kamut®), barley and rye contain gliadins and glutenins and are, therefore, not suitable for coeliacs, even in their wholemeal versions.

The nutrition claim “gluten-free” may only be added to the label if the gluten content of these products is below 20 ppm (equivalent to 20 mg per kg of product). Recently, a gluten toxicity different from coeliac disease has been codified and defined as non-coeliac (gluten sensitivity),

a condition associated with non-specific abdominal problems, but without the intestinal lesions typical of coeliac disease. This clinical picture goes into remission with the elimination of gluten/wheat from the diet. But it is still unknown exactly which compounds trigger this reaction. Recent studies identify amylase-trypsin inhibitors (ATIs) and so-called FODMAPs (fermentable oligo-, di-, monosaccharides and polyols) as other possible causes or concomitant triggers of gluten sensitivity. The response to wheat elimination is usually rapid and brings about significant clinical improvements in a matter of days. It is important to emphasize that the

FROM THE LAND OF WHEAT  
· SINCE ·  
**PASTA  
ARGENTINA**  
· 1860 ·

*La mejor Pasta de  
Sudamérica*



VIENE DE  
NUESTRO TRIGO



SALE DE  
NUESTRO CORAZÓN



gluten-free diet cannot and must not be considered as a trend: it is not a slimming diet nor is it lighter than the gluten diet, but it must be considered as a therapy, i.e. a health aid for a chronic systemic disease for those who are unlucky enough to suffer from it.

## **Ancient and modern varieties**

Today, there has been a revival of ancient types of wheat, to which positive characteristics have often been attributed, to the detriment of modern wheat. Hard wheats such as Timilia or Russello (two local Sicilian populations) or Cappelli (the first variety of durum wheat released by Strampelli in 1915), or soft wheats such as Gentil Rosso or Verna (two local populations cultivated in central and northern Italy in the 19th century) are being cultivated once more, and products made from the flour of these ancient grains are increasingly found on the market. But what is the effective difference in the seed composition – and hence the flour – of ancient versus modern wheat?

Modern wheat has less protein and therefore also less gluten than ancient wheat. Protein content depends on both genetic and agronomic factors (nitrogen fertilisation), but in general a negative correlation is observed between increased

production and protein content in the seeds. Agronomic conditions being equal, ancient, less productive wheat has more protein and more gluten, but there is nonetheless a certain genetic diversity whereby individual varieties (both modern and ancient) may deviate from the general trend. An important difference between ancient and modern wheat resides in the quality of the gluten. Generally speaking, genetic improvement has led to an increase in gluten strength, and the selection of wheat with tenacious gluten has been motivated by the consumer's increasing propensity for soft breads and al dente pasta.

Although modern wheat generally has more tenacious gluten than ancient wheat, it is important to point out that modern wheat varieties, of soft wheat in particular, are by no means all the same. There is a range of selected varieties for producing flours with various technological properties suitable for different uses (biscuits, different types of bread/pizza, highly leavened cakes, etc.). Modern soft wheat varieties are, in fact, ranked in four product classes, based on protein content and gluten tenacity characteristics. Ranging, therefore from “biscuit” wheat characterised by a particularly low protein content (<11%) and weak gluten to

“strong” wheat, characterised by a particularly high protein content (>14%). All wheat contains gluten and short protein tracts (epitopes) capable of triggering a coeliac reaction in sufferers. There is some evidence that diploid wheat varieties (monocot) have fewer toxic epitopes than tetraploid wheat (durum, emmer) and that tetraploid has fewer than hexaploid wheat (soft wheat and spelt), but no kind of wheat can be consumed by people with coeliac disease. Recent studies show that the content of epitopes capable of inducing the coeliac response is highly variable in both ancient and modern wheats, and there is no trend towards an increase in these epitopes as a result of genetic improvement.

In conclusion, in discussing ancient and modern wheat, some practical considerations should be made. Due to their low productivity (about half that of modern wheat), ancient wheats require a much larger surface area to produce the same amount of flour, and this is clearly in contrast with the principles of environmental sustainability. In Italy, the approximately 600,000 hectares cultivated with modern soft wheat are sufficient to produce around 40% of the flour used annually. If the whole Italian area of soft wheat were cultivated with ancient wheat, national soft wheat production would fall

to around 15-20% of the nation's requirements, and the remaining 85% would have to be met by importing modern wheat from abroad. The same applies to durum wheat, where domestic production covers approx. 60% of national requirements. Of course, these considerations do not imply that ancient wheat should disappear, but that it should be considered an opportunity only for marginal areas (where the productive difference between ancient and modern wheat is smaller) and promoted for its historical/cultural value but not for non-demonstrated agronomic or nutritional characteristics.

## Note

To find out more: Luigi Cattivelli, *Pane nostro. Grani, farine ed altre bugie*. Edizioni Il Mulino, 2023.

**ANSELMO**



**ANSELMO  
BRAIBANTI**



**FEN**



**ANSELMO  
LTA**



**OMAR**

**5 technologies**

perfectly matched  
to be your partner  
for **dry pasta, fresh pasta and snacks**

**ANSELMO GROUP**

*complete solutions for food industry*

[www.anselmoitalia.com](http://www.anselmoitalia.com)

**ANSELMO IMPIANTI SRL** - Via Fossano, 33 - Bene Vagienna (CN) - ITALY | Tel. +39 0172 654755 - Fax + 39 0172 654811

**LTA** - Via dell'Industria, 11 - Thiene (VI) - ITALY | Tel. +39 0445 370993 - Fax +39 0445 813114

**FEN IMPIANTI SRL** - Via Sole, 72 Tezze sul Brenta (VI) - ITALY | Tel. +39 0424 868711 - Fax +39 0424 868777

**OMAR IMPIANTI SRL** - Via Stelloni, 39/I - 39/O - Sala Bolognese (BO) - ITALY | Tel. +39 051 6814821 - Fax +39 051 727354